

# review

special report

## Transformers



- 06–27 **Smarter**
- 28–45 **Greener**
- 46–63 **Stronger**





37

Transformer energy efficiency



22

Transformer asset management

Transformers to meet special needs



51

Ecological oil-free transformers



28



46

## Quality power with shunt reactors



55

## UHVDC and UHVAC transformers



06

## TXplore robot inspects transformers

---

## 05 Editorial

---

## Smarter

- 06 TXplore robot inspects transformers
- 13 ABB Ability Power Transformer
- 18 ABB Ability TXpert
- 22 Transformer asset management

---

## Greener

- 28 Ecological oil-free transformers
- 33 Eco-efficient ester liquid transformers
- 37 Transformer energy efficiency
- 42 Transformers in renewable applications

---

## Stronger

- 46 Quality power with shunt reactors
- 51 Transformers to meet special needs
- 55 UHVDC and UHVAC transformers
- 60 Transformers for Indian Railways

---

## 63 Imprint

---

**In an increasingly digitalized world, ABB is at the forefront of driving the energy revolution. Technologies like transformers are shaping a stronger, smarter and greener grid.**

**ABB Ability™ - based power and distribution transformers are allowing power grids, industries, infrastructure and transport sectors to be managed with higher reliability, safety, efficiency and intelligence.**

## EDITORIAL

# Transformers



**Markus Heimbach**  
ABB Transformers  
Managing Director  
Transformers business unit

Dear Reader,

For over 100 years, ABB has pioneered the transformer technology that continues - now even more than ever - to play a pivotal role in the running of the power grids that work day and night to keep society going.



**Stephane Schaal**  
ABB Transformers  
Technology Manager  
Transformers business unit

Transformers can be found wherever electricity is generated, transmitted, distributed and consumed. Their primary function is to “transform,” or, adapt, voltage levels - stepping up for long-distance high-voltage transmission - and stepping down for distribution to consumers.

The grid continues to increase in complexity, integrating more clean and renewable energy than ever before, while balancing new loads, like electric vehicle charging and data centers, inspiring innovative transformer technology from ABB engineers.

Quantum leaps in transformer technology have been taken by ABB in the areas of digitalization, asset life-cycle management, energy and eco-efficiency, ultra-high-voltage DC and AC applications, and transformer resiliency providing protection from extreme weather events and physical security.

Please enjoy this report on the latest transformer innovations to see why ABB is a partner of choice for enabling a smarter, greener and stronger grid.

Let's write the future together.

A handwritten signature in red ink, appearing to read 'M. Heimbach'.

**Markus Heimbach**  
Managing Director  
Transformers business unit

A handwritten signature in red ink, appearing to read 'S. Schaal'.

**Stephane Schaal**  
Technology Manager  
Transformers business unit

SMARTER

# ABB's TXplore robot redefines transformer inspection

ABB's new validated robot inspection system, TXplore, is tailored to the complex oil-filled transformer environment. Rigorous testing provides overwhelming support of robotic over human internal inspection in terms of cost, safety and digital leverage.

**Gregory Cole**  
**Harshang Shah**  
ABB USCRC Mechatronics  
and Sensors Bloomfield,  
CT, United States

gregory.a.cole@  
us.abb.com  
harshang.shah@  
us.abb.com

**Craig Stiegemeier**  
ABB Transformer  
Remanufacturing and  
Engineering Services  
St. Louis, MO,  
United States

craig.stiegemeier@  
us.abb.com

**Jamie Stapleton**  
ABB Transformers  
Business Unit  
Worthing, United  
Kingdom

jamie.stapleton@  
gb.abb.com



—  
01 TXplore remotely driven robot uses propellers and buoyancy control to navigate freely; light sources and cameras secure quality images.

—  
02 Oil-immersed power transformer can be taken out of service and inspected without the need to drain the oil.

—  
03 An in-situ internal inspection of a transformer showing the robot pilot, equipment manager and the robot.



02

Despite the use of non-invasive condition monitoring techniques to determine possible faults and avoid adverse failures in oil-immersed transformers [1], there are routine and emergency situations that require costly internal inspections with major risk to both transformer structure and human inspectors. Nowadays, utilities perform internal visual inspections following lightning strikes and when there is the need to isolate the exact location or severity of a fault, multiple faults or complete a planned repair [2].

In cases such as these, the mineral oil must be removed and stored so that a highly skilled transformer inspector can enter the hazardous enclosed space of the transformer tank, risking damage to both the inspector and transformer. The inspection process also requires medical teams and other expert personnel to be present. Commonly, during inspections, transformer downtime is three days – seen overall, internal human inspection has high human and capital costs.

With over 200,000 projects completed, ABB is a global leader in the production, monitoring and maintenance of transformers. Much thought has been devoted to internal inspections of these devices with the aim of lowering capital costs, improving the effectiveness of inspection data, lowering the safety risk to humans and transformer assets and reducing downtime.

In late 2012, ABB proposed a concept to develop a remotely driven robotic system to operate reliably and effectively within the toxic and fragile environment of a transformer unit and eliminate the need for human inspection. To be a viable option for utilities, the remotely driven robotic system must inspect the transformer, navigate effectively and maintain the integrity of both the transformer and its oil. High quality visual images and data must be collected and transmitted to external systems for evaluation. A multi-disciplinary team of scientists and engineers from ABB was formed to design such a system.



Equipment manager



Device inspection



Robot pilot



03

The result of their efforts is the submersible transformer inspection robot now known as TXplore →1.

#### Technical development and validation of TXplore

Power transformers are expensive yet critical machines that are designed and manufactured using complex engineering and construction methods to deal with stressors encountered during their lifetime - eg, overvoltage, short-circuit currents, high temperature of windings and contaminants. The circulation of insulating oil allows heat to be removed from the windings and is crucial to the health of the transformer. Any object, including a robot, which enters the transformer must preserve the integrity of the oil. For this reason, ABB designed the entirely new TXplore system →2.

#### TXplore system design

The newly designed inspection system for de-energized transformers only requires two personnel once the unit is prepared: a top-side equipment technician to setup and manage the robot and a robot pilot to navigate, gather data and communicate with experts and customers →3. The equipment operator is responsible for the installation tasks and placement of the robot into or out of the system →3.

TXplore is designed to navigate and collect high quality inspection data safely and easily. The photos and videos can be produced without becoming stuck or damaging the transformer or its components →4. The tetherless robot is shaped and sized to balance ease of navigation with robustness, which allows the submersible robot to inspect all areas of interest such as bushings, leads, tap changer, core top, core support and insulation and more. Additionally, redundant safety systems and extensive thermal and environmental safety testing verify the TXplore system is ready to inspect transformers under a variety of demanding conditions.

With the preservation of mineral oil quality of primary importance, the robot construction is optimized to leave no detectable footprint – either chemical or physical – as it operates within the transformer. The robot's outer shell is made of a high performance plastic that minimizes the risk of electric coupling and structural damage to the transformer while allowing the craft to operate safely in demanding environments at high temperatures.

—  
03 An in-situ internal inspection of a transformer showing the robot pilot, equipment manager and the robot.

—  
04 Examples of the results given by numerical simulations.

04a Temperature distribution.

04b Velocity streamlines.

04c Temperature isosurfaces.

—  
05 Temperature distribution along conductor. Comparison of 3-D numerical model and heat run test results.

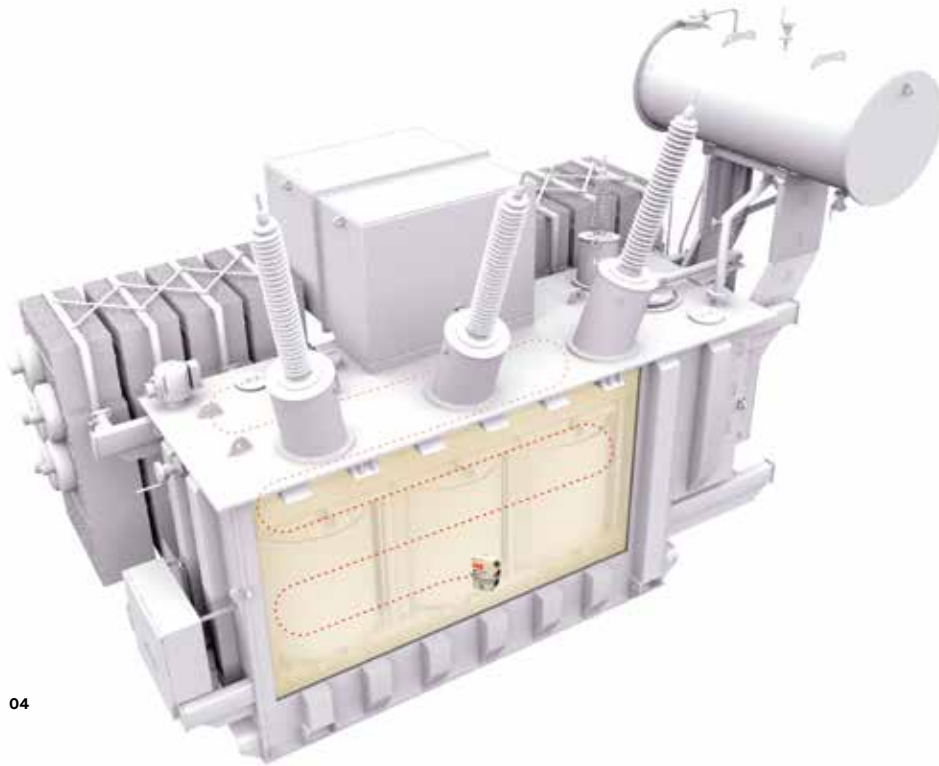

04

High quality inspection images can be made on-site and transmitted worldwide. Redundant radio systems ensure that navigation can continue even when communications are impaired. The unique system architecture allows future technologies to be added as advances are made and end user demand grows →5.

In this way the TXplore system provides digital leverage.

**Human versus robot**

The safety of the people responsible for inspection and the integrity of the transformer are paramount and the system design ensures optimal navigation and communication ability. A comparison of the proposed workflow to conduct a robot inspection with that of a traditional human invasive inspection indicates this →6. TXplore navigates in the oil, thereby eliminating the need for processing equipment eg, tanker trucks, processing and vacuum filling rigs or personnel to remove and store the oil – a common practice during human inspections.

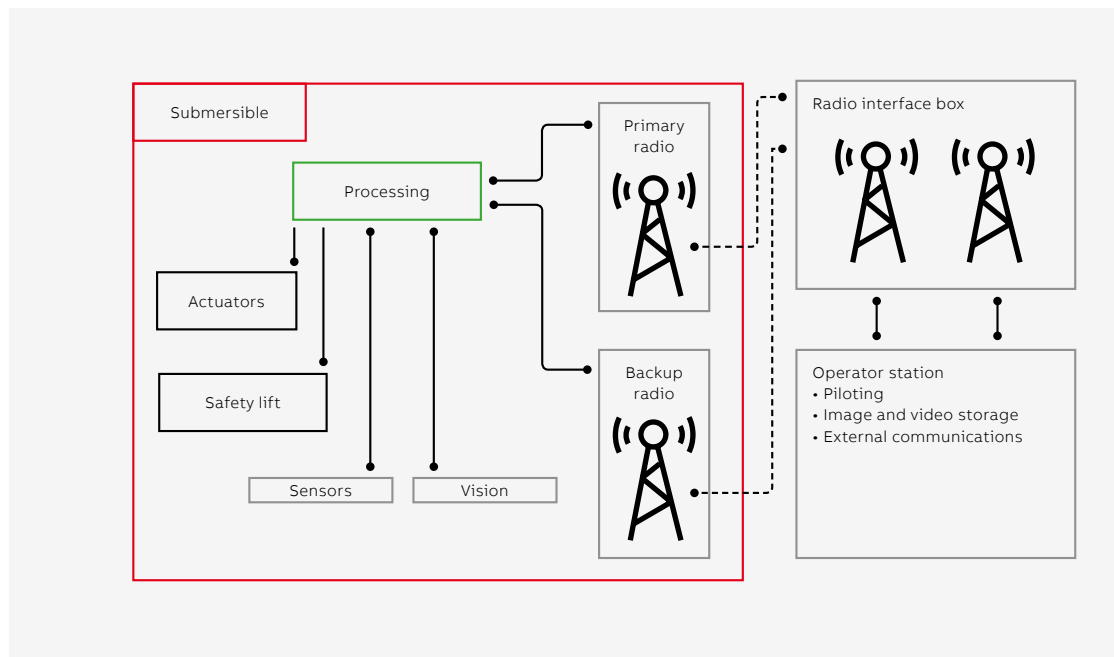

05

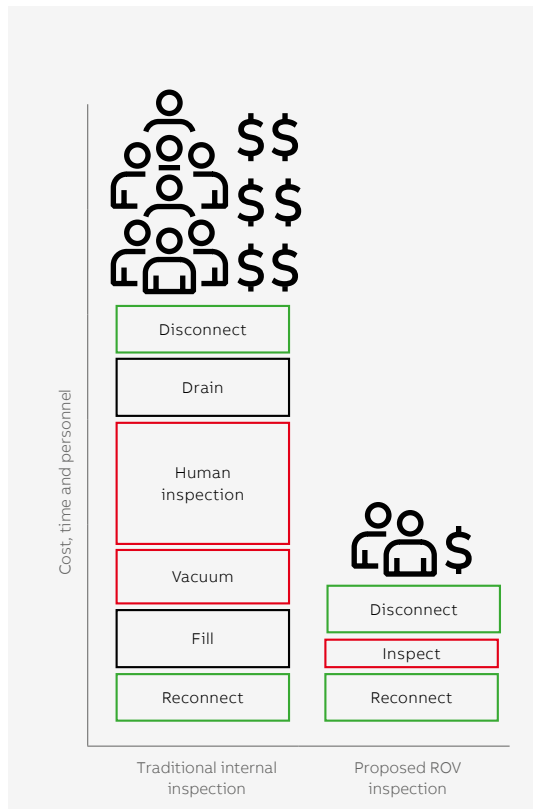

06

And, because the robot enters the unit instead of a human, no medical or environmental safety team is required during inspection. Remarkably, only two employees, a robot pilot and a top-side equipment operator, are needed on-site during a TXplore inspection, once the transformer has been prepared →3. Overall, robotic inspection can be completed in less than one day with only two employees – a dramatic reduction in personnel, time and cost compared to a standard human inspection, which requires a large team and lasts three or more days.

**Validation**

Whole system and subsystem investigations were undertaken in the laboratory and at testing facilities before pilot studies were conducted in near-real-world installations. Tests were performed for leakage, navigation capability, temperature and chemical stability and possible oil contamination. Prototypes were tested for leakage at various temperatures for more than 96 hours under pressure conditions that reached up to more than twice the expected field pressures. Spatial and depth navigation abilities were assessed in seven different oil-filled tanks to determine robot stability and to ensure that visual system could be stabilized to support high quality images.

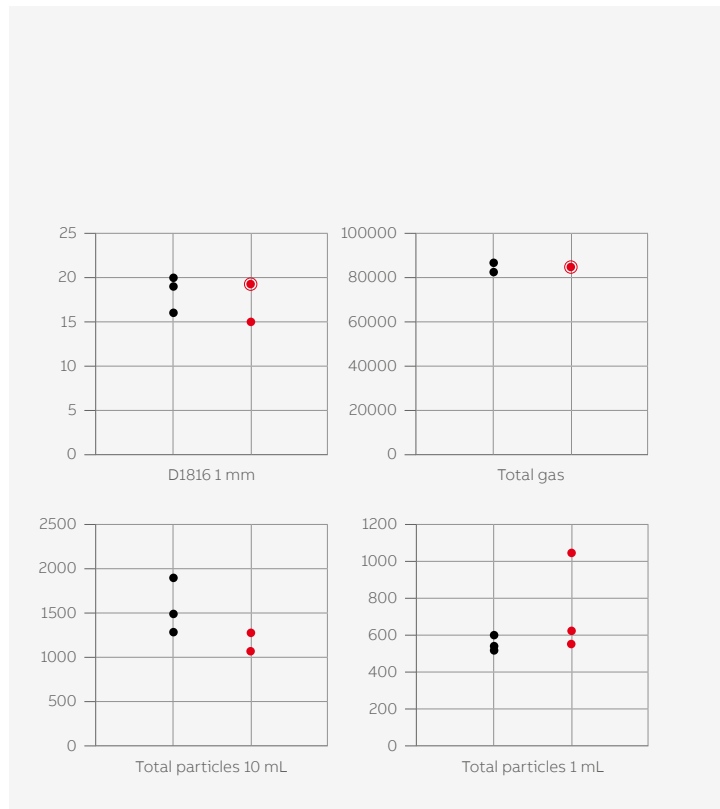

07

The impact of the robot prototype on the mineral oil was evaluated in an elegant way: Two tanks of oil were prepared, one with a volume of highly contaminated oil (taken from a field transformer) and one with 100 gallons of clean oil. A baseline set of measurements were made for volumes of oil. The robot was then placed in the tank of highly contaminated oil for 6 hours. The robot was removed and re-processed using ABB’s validated cleaning and site preparation techniques.

Afterward, the remotely driven robot was placed in the clean oil tank for an extended period. At this point samples were retrieved from this oil tank and analyzed to ascertain whether or not the robot contaminated the second oil tank. The results were then compared to the baseline results.

—  
06 Current human workflow versus proposed robot workflow for a transformer inspection.

—  
07 An example of oil contamination test results showing no particulate contamination following introduction of the robot in the oil-immersed transformer.

—  
08 Images taken by TXplore during an inspection of a 20 year old transformer that had tripped off line.  
08a The customer thought the source of failure could be the tap changer but TXplore image shows this is not the case.  
08b TXplore image shows clearly that a disk to disk failure was the source of the problem.

The contamination level of the oil (from clean and new to practically black and highly contaminated with particles present) →7, temperature (from -5 °C to 27 °C) and the impact of the robot on the oil were examined. The findings show that the oil maintains its integrity throughout the inspection process if procedures are followed.

It is known that remotely operated vehicle (ROV) propulsion systems often generate bubbles through cavitation. Design elements were carefully included to prevent this. For example, the propulsion system of the robot can be a source of cavitation. A stroboscopic investigation of the propeller was performed at all possible rotational frequencies to evaluate this process. There were no gas bubbles detected, even in areas likely to act as cavitation nucleation sites such as the leading edge of the propeller or the gap between the propeller and shroud.

Pilot system inspections were conducted under various conditions and temperatures; the result was a dramatic reduction in inspection time to less than two-hours. Clear and accurate images were taken →8, recorded and provided to the customer in the form of a detailed report that documents the inspection. All relevant information could be shared with experts worldwide in near-real-time. This capability ensures customer will have the right diagnosticians to deal with any transformer issues encountered. TXplore inspection allows a return to service with confidence that the future plan of operation or repair of the transformer asset can be maintained.

### Case study

Robotic inspection test results have been reaffirmed by transformer inspections conducted in 2016 at the St. Louis power transformer factory on production transformers and on a critical substation that provides power to the high-voltage test facility →9.

Additionally, American Electric Power (AEP), a large utility in the United States, viewed a demonstration of a remotely driven robot inspection of a tank at ABB Customer World in March, 2017. AEP approached ABB about the possibility of performing an inspection of one of their large power transformers that would be taken out of service.

During the summer of 2017, ABB's development team brought the robot and control and recording equipment to the AEP station and successfully performed an internal inspection of a transformer that was more than 50 years old without the need for any oil handling. TXplore successfully inspected the transformer and ABB could verify the benefits of effective mobility of the robot, visualization ability and collaboration potential, both remote and local, as well as the efficient overall operation.



08a



08b

—  
 09 The Txplore transformer inspection process is shown.  
 09a A demonstration of a remotely driven robotic inspection within an oil-filled tank.  
 09b The inspection utilizes a top-side equipment technician to set-up and manage the inspection and a robot pilot to navigate.  
 09c TXplore is safely placed into the oil-filled transformer by a top-side equipment technician.  
 09d TXplore navigates freely and safely within the oil-immersed transformer without risk to employees.

—  
**References**  
 [1] L. Carlzon, A. Fazlagic, P. Lorin, Service Handbook for Transformers, P. Boss, G. Frimpong, and M. Turner, eds. ABB, 2007.  
 [2] H.C Sun, Y.C. Huang, C.M. Huang, "A review of dissolved gas analysis in power transformers" Energy Procedia, volume 14, pp. 1220-1225, 2012.

**Product Launch**

Prototype data and performance information were reviewed following these pilot inspections. As a result, design modifications were made to improve reliability, longevity and to enhance the ability of TXplore to perform inspections in hot oil. The first production robots were initially tested and completed trial inspections in February 2018. The robot was introduced to the market at the Hanover Trade Fair and initial orders for pilot trials of the final design were received March 1. Production service inspections are scheduled to begin in May 2018. From this time forward robot production will allow global ABB to perform inspections on any oil-filled transformer large enough to accommodate the patented robot. Production will continue to enable a fleet of robots to support ABB service operations.

**The future is safe and digital**

Robotic inspection eliminates the need to bring in heavy equipment and reduces the size of the supervisory team, dramatically shortens downtime, usually to under a day, and is cost-effective. Moreover, the ability of the system to provide a comprehensive inspection data set make robotic inspection beneficial.

Nevertheless, the most significant advantage of using a remotely driven robot to navigate the oil is the ability to visually map the entire interior of the transformer unit and remotely view the inspection results safely without requiring humans to enter the enclosed space of the transformer. ABB takes this advantage one step further and will integrate the robot and system into the ABB Ability Platform. The forthcoming digital solutions and services will be built around the inspection data.

By revolutionizing oil-immersed transformer inspection, not only has ABB anticipated the customers' desire to improve safety and lower costs, they have transformed inspection data gathering and management to provide digital leverage to customers and that all important competitive edge. ●



09a



09b



09c

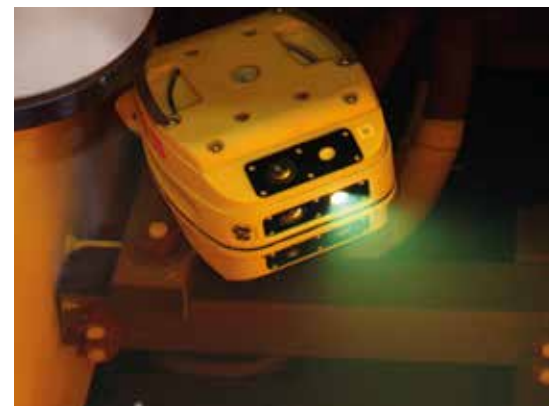

09d

---

**SMARTER**

# The ABB Ability Power Transformer sets new industry standards

With its standard digital capabilities, the ABB Ability Power Transformer provides a future-proof platform that delivers health data and actionable intelligence. Users gain access to ABB's digital ecosystem and can thus optimize reliability, availability and productivity while improving capital efficiency.

**Helmut Bockshammer**  
ABB Transformers  
Ratingen, Germany

helmut.bockshammer@  
de.abb.com

**Andrew Collier** ABB  
Transformers  
Bad Honnef, Germany

andrew.collier@  
de.abb.com

**Miguel Cuesto**  
ABB Transformers  
Cordoba, Spain

miguel.cuesto@  
es.abb.com

The power landscape is predicted to change more in the next 10 years than it has in the last 100 [1] →1. This is mostly due to the change in generation mix, where the integration of renewables and distributed energy resources is having the double impact of adding volatile supply sources while causing a decline in traditional high-inertia generation such as coal. This volatility will increase further, on the demand side, as e-mobility plays a greater role in the near future. At the same time, many utilities and industrial companies are under pressure to increase

their efficiency and productivity in order to remain competitive in their respective fields.

Power transformers are critical elements in the electrical grid infrastructure that are impacted by these changes in the grid. While nobody can predict the exact effects on the typical power transformer over its lifetime of 30 to 50 years, it is certain that changing demand patterns will result in a more dynamic loading of the transformer, which can be detrimental to its remaining life →2.

**01**

---

01 The ABB Ability Power Transformer delivers health data and actionable intelligence so users can optimize reliability, availability and productivity while improving capital efficiency.

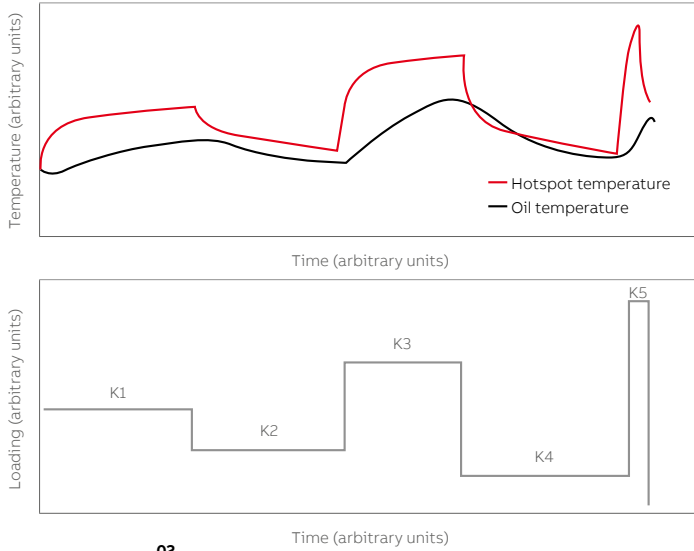

02

To address this situation, users need actionable information and insights to enable better decision making and asset management as well as a future-proof technology concept. Therefore, the time has come for transformers to become digital by design. This is why ABB has developed the ABB Ability Power Transformer (AAPT) as a new standard for power transformers. The AAPT is an integrated solution with electronic temperature monitoring and on-board intelligence on load and aging conditions. →3. Additionally, the AAPT offers a wide range of options, leveraging ABB’s broad portfolio of devices, software and services.

**Digital power transformer platform and ecosystem**

The technical development of the AAPT was based on a future-proof modular solution. The platform concept covers everything from the standard package with electronic temperature monitoring and indicators, up to a full monitoring package with plug-and-play connectivity including the whole family of ABB eDevices (digitally enabled instrumentation and protection devices), ABB’s dissolved gas analyzers (DGA) CoreSense and CoreSense M10, and the option to integrate third-party sensors and instrumentation. →4-5.

Upstream connectivity options range from local devices such as laptops or tablets, control or SCADA (supervisory control and data acquisition) systems, to ABB’s own ABB Ability Ellipse asset performance management (APM) software.

Even just the standard AAPT configuration brings the benefit that multiple data points can be trended and stored for future reference or used to compare the relative performance of parallel units and aid in future planning. The AAPT also includes a self-check or watchdog function.

The AAPT platform has been conceived to be independent of the type and size of the transformer, as the accessories defined for the standard package are typically used in every oil-immersed power transformer.

03

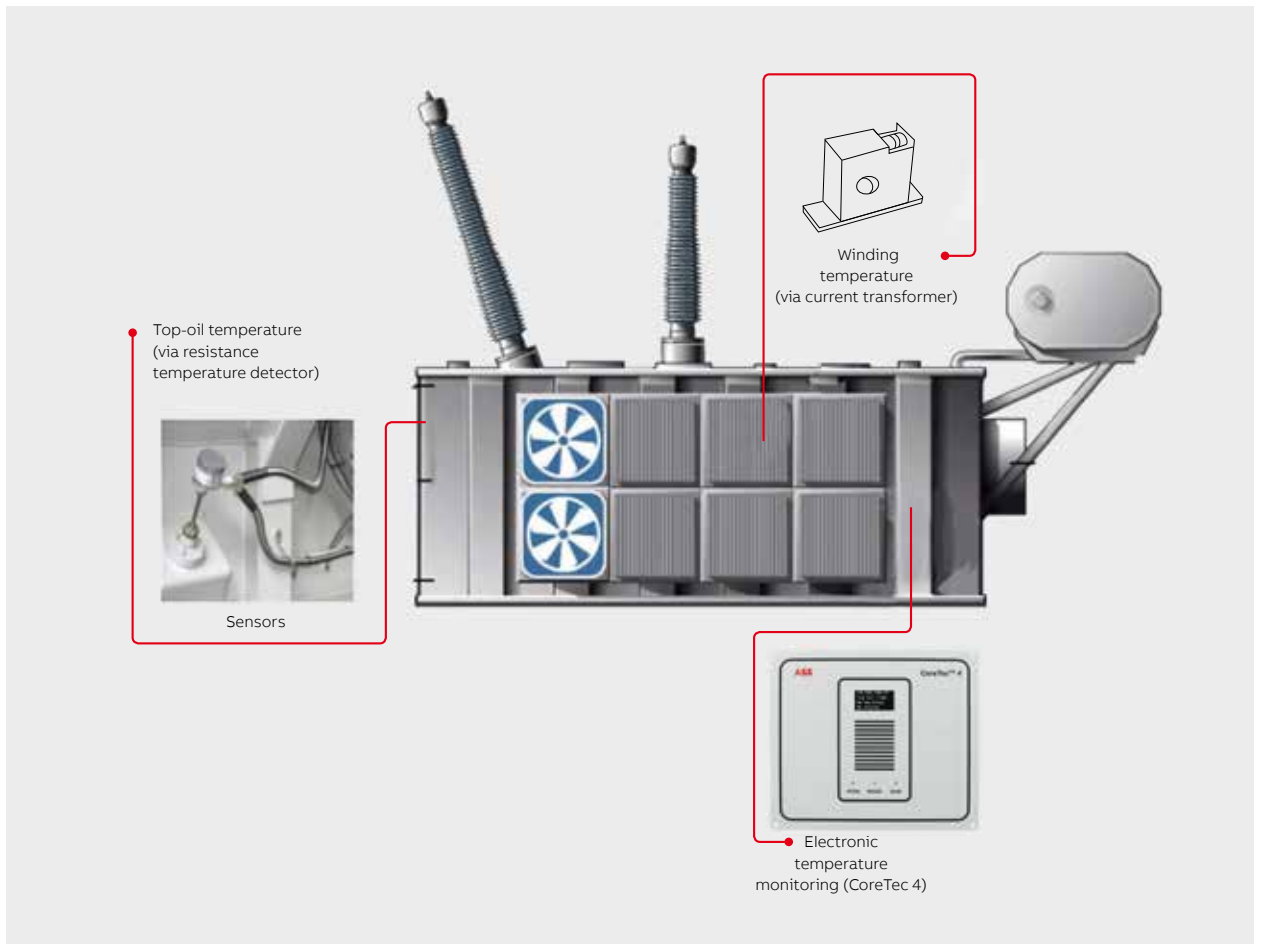

**eDevices**

Product type	Description
eSDB	Self-dehydrating breather
eOTI	Liquid temperature indicator
eWTI	Winding temperature indicator
eOLI	Liquid level indicator
eVIEWER	Remote viewer for eOLI
eBR	Buchholz relay
ePRD	Pressure relief device

**Dissolved gas analyzers**

Product type	Description
CoreSense	Hydrogen and moisture monitor
CoreSense M10	Monitor for nine different gases and moisture

**04**

—  
02 Transformer loading behavior: As the transformer loading increases, there is an offset in the oil's ability to transfer the additional heat, which leads to increased hotspot temperature.

02a Oil temperature level and hotspot temperature.

02b Transformer loading.

—  
03 The standard ABB Ability Power Transformer offering.

—  
04 DGA and eDevices.

The design models, drawings, installation and operating instructions, plus functional and installation tests are compatible with any power transformer and have been defined with this global requirement in mind. Last, but not least, the AAPT is fully compliant with industry standards applicable to both power transformers and low-voltage controls for any region of the world.

**Connectivity**

Many customers now demand actionable information, intelligent asset optimization and the ability to use real-time data to mitigate “nasty surprises.” The potential to network the AAPT is, therefore, a driver for many customers. The transformer can easily be connected to the station control via a built-in Ethernet cable and fiber-optic interfaces or via wireless. All connectivity solutions are supported by state-of-the-art cyber security and options include connection to ABB Ability cloud-based services.

Today, not everybody wants their most critical assets connected to the outside world. So, independent of the onboard cyber security, transformer monitoring can operate in on-premise or in standalone mode. Customers may send ABB raw data for interpretation and translation into useable information. Alternatively, customers can utilize ABB's expertise on site.

**Winding temperature**

The beating heart of a power transformer is its windings, but traditional methods for controlling transformer cooling are based on monitoring the oil temperature rather than what is actually happening at the transformer's hotspot. The aging of the insulation at the hottest point in the winding typically determines the life span of a power transformer; an oil temperature just 8°C above nominal could reduce the insulation life by up to 50 percent [3] →6.

The AAPT's modern Electronic Temperature Monitoring solution can accurately calculate the transformer's hotspot based on design data and factory type-test results, together with dynamic variables such as the loading and oil temperature. This can then be used to regulate the transformer's hotspot temperature.

**CoreTec™ 4**

The brain of the AAPT is the CoreTec 4 module. CoreTec 4 is a digital hub, responsible for collecting and analyzing readings from the different sensors, and processing them to provide an assessment of transformer operation (including cooling equipment governance, if needed) and life expectancy.

For the development of CoreTec 4, ABB was able to leverage existing expertise and experience in transformer monitoring systems, building on developments that go back to the 1980s with first fiber-optic temperature monitoring systems, the 2000s with Transformer Electronic Control (TEC) and the previous CoreTec generations.

Apart from functionality, additional design requirements such as compactness, expandability (by plug-ins), ease of installation and durability were considered in the development process.

To ensure system robustness, demanding mechanical, thermal and dielectric laboratory trials were carried out. Mechanical testing covered not only vibration but also thorough seismic and shock tests (over 10 G). Thermal validation was achieved in steady-state conditions and in contingency situations, such as when cabinet cooling is lost. All these validation tests had positive results – the readings were consistent during the tests with no interruption, no visual damage and successful operation after the tests.

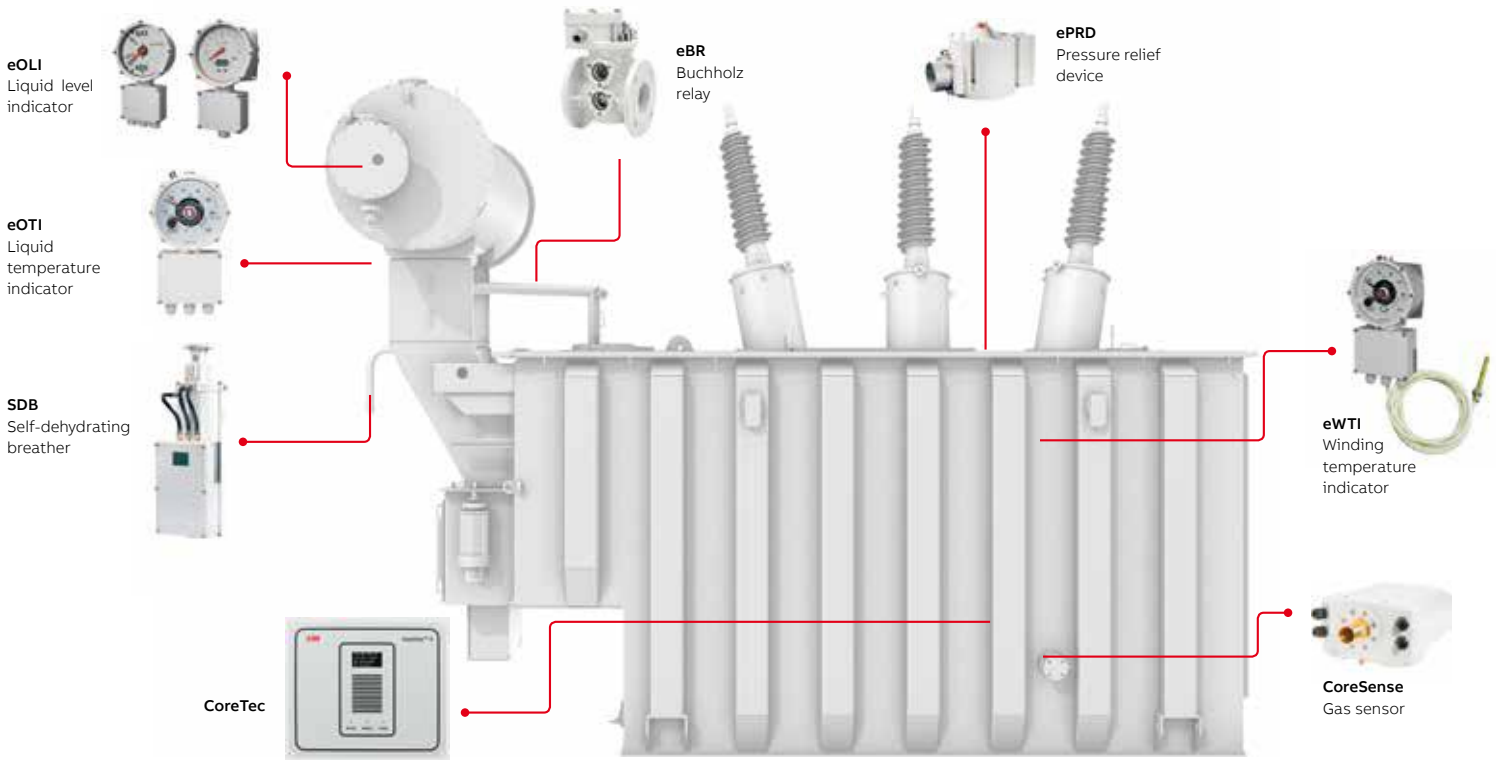

05

The AAPT has been validated as an integrated solution in several new and retrofit applications of different types. The validation included thousands of hours of real on-site conditions, at different locations and applications around the world. Data gathered during validation demonstrated reliable performance, with all functional parameters within expected ranges, confirming the benefits of the measurement analysis. Indeed, the owners of these pilot units have started to see the benefits of the AAPT technology by making use of the advanced analytics to translate the collected data into actionable information.

**Field experience**

Various use cases were identified and proven in the field. In a transmission network, the information provided on temperature and load enabled the operator to optimize the cooling control in such way that the top oil temperature fluctuation was reduced from over 15 °C to less than 5 °C, under varying ambient and load conditions. This results in stable conditions for the insulation and extends the transformer’s lifetime.

In an industrial installation, the operator noticed an increase of temperature and dissolved gases while the load was constant. An investigation found a that a mineral buildup had resulted in a faulty fan at a heat exchanger – a situation that could have proven costly in the long run.

In a smelter application, the customer wanted to increase their production capacity by 15 percent. Thanks to the digital capability it was possible to calculate the trade-off in terms of remaining transformer life, and to ensure the asset integrity while running the transformer in overload condition.

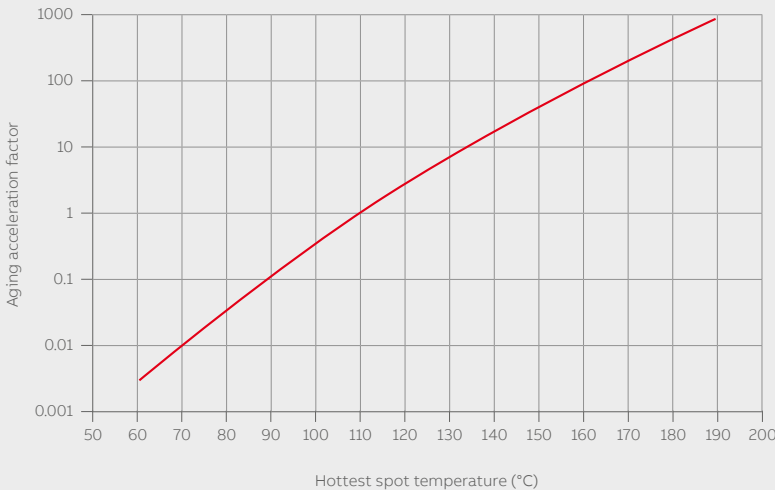

06

—  
05 Transformer with eDevices.

—  
06 Even moderate overtemperatures have a significant detrimental effect on transformer lifetime. [2]

—  
07 Summary of the concept and benefits of the ABB Ability Power Transformer.

**References**

[1] World Economic Forum, with analytical support from McKinsey & Company, "Fostering Effective Energy Transition A Fact-Based Framework to Support Decision-Making." Available: [http://www3.weforum.org/docs/WEF\\_Fostering\\_Effective\\_Energy\\_Transition\\_report\\_2018.pdf](http://www3.weforum.org/docs/WEF_Fostering_Effective_Energy_Transition_report_2018.pdf)

[2] ABB Data Manifesto. Available: <https://www.forbes.com/sites/abb/2017/04/13/a-call-to-action-for-the-internet-of-things-industry-lets-write-a-data-bill-of-rights-for-cloud-customers/#7d4731829a21>

[3] Institute of Electrical and Electronics Engineers, "IEEE Std. C57.91: Guide for Loading Mineral-Oil-Immersed Transformers and Step-Voltage Regulators," 2011.

In the future, with more data becoming available from an expanded base of installations, and with the advancement of analytics technologies, additional use cases will emerge that further leverage the digital capabilities and the ecosystem that ABB can provide.

**The future of power transformers is digital**

In the past, transformers were an asset that kept running under stable conditions in a centralized grid. The exact condition of the transformer, especially that of its insulation and aging, were not known but due to stable load conditions many transformers had a long lifetime. Today, however, grid conditions have become more stressful due to the integration of volatile renewables and distributed energy resources, and, for example, the rise in the number of electric-vehicle charging stations.

Additionally, asset owners feel pressure to ensure competitiveness and effective allocation of capital and operational expenditures. Therefore, better insights are needed in order to ensure sound decisions on transformer maintenance, repair or new investment.

Further, those armed with the right data interpretation can benefit from dynamic optimization of the transformer loading and reduce the need for site visits. They can make informed decisions and trade-offs between overloading the transformer for immediate financial gains versus shortening transformer life.

ABB is enabling asset owners to meet all these challenges by digitalizing new transformers as a standard feature. The ABB Ability Power Transformer monitors health data and delivers actionable information to enhance grid reliability and the efficiency of load distribution, and increase service and maintenance productivity by enabling condition-based maintenance.

During the lifetime of the transformer, upgrades are easily possible thanks to a modular and scalable architecture. Therefore, the ABB Ability Power Transformer is a future-proof investment designed to open the world of digital possibilities to asset owners and enable them to gain a competitive edge in a changing environment →7.

The AAPT was introduced to the public at the Hannover Messe 2018 and garnered positive reactions and feedback. The market launch of this new product underlined how ABB has, throughout its long history, been able to solve important customer problems, deliver real benefits and spearhead innovation. ●

07

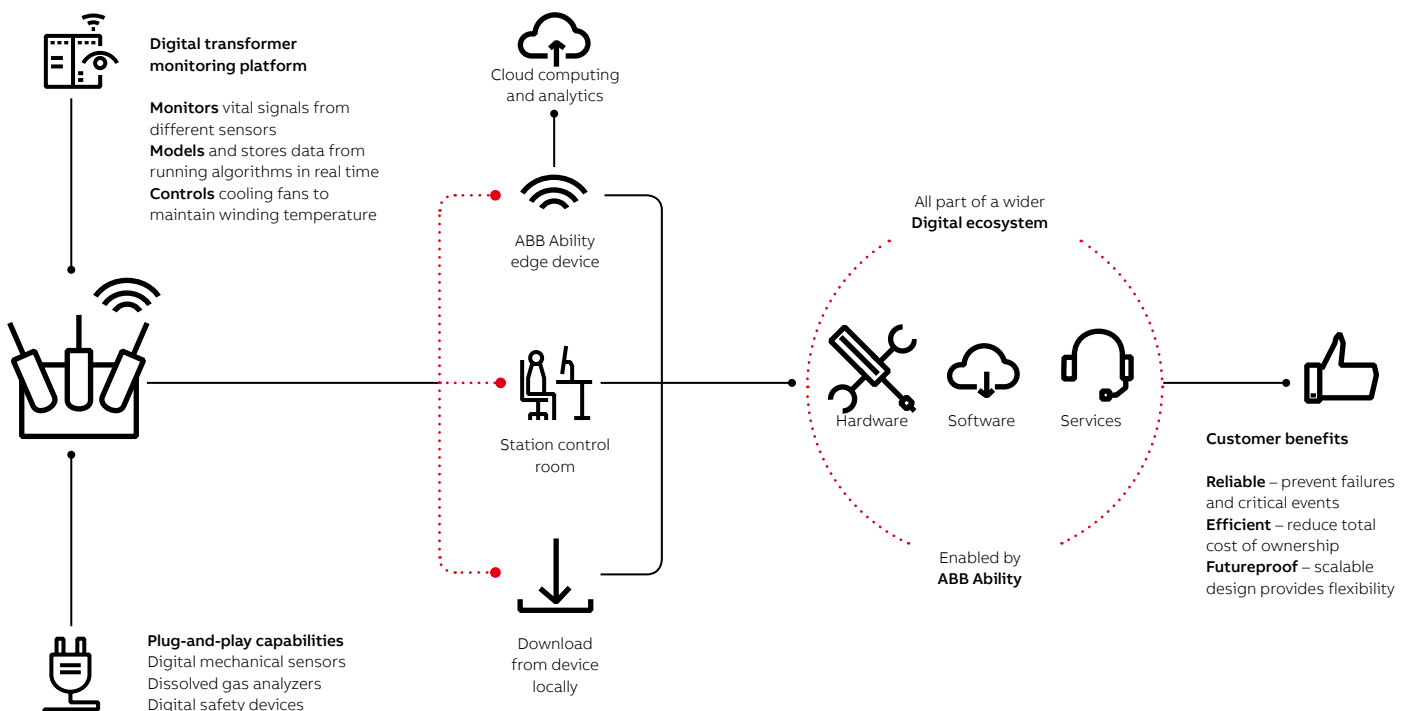

SMARTER

# Dawn of the digital distribution transformer

ABB's ABB Ability TXpert is the world's first truly intelligent distribution transformer. TXpert combines ABB's world-class transformer expertise with digital technologies and advanced analytics to give customers actionable insights into transformer and grid health.



**Deidre Cusack**  
ABB Transformers  
Business Unit  
Raleigh, NC, United States

deidre.e.cusack@  
us.abb.com

Distribution utilities are dealing with far more complicated power grids than ever before. Unprecedented challenges are posed by a bewildering array of factors: rapid expansion of cities and urban areas; incremental grid upgrades; the addition to the grid of renewable generation sources such as solar and wind; and the inclusion of unique loads such as electric vehicle (EV) charging stations. These changes stress distribution transformers – the vital link between the electrical grid and homes, industries and infrastructure – and can result in premature failures, unplanned outages and less-than-optimal grid operation.



**Deia Bayoumi**  
ABB Transformers  
Business Unit  
Raleigh, NC, United States

deia.bayoumi@us.abb.com

Uptime, safety and the environment are major concerns for operators of, for example, data centers, oil and gas installations, and industrial plants. To handle these concerns, such enterprises maintain their equipment through condition-based asset management systems. Now, to further improve reliability and to protect themselves from the stresses described above, these operators are interested in integrating their electrical equipment, such as transformers, into these systems.

This interest – and the need for faster decisions, real-time action, and improved reliability of distribution transformers – led ABB to explore how to exploit digital technologies to produce a new distribution transformer that would enable customers to address not just today's challenges but also those of tomorrow.



01

**ABB Ability TXpert development**

Starting from a blank sheet of paper, an open innovation process was begun in ABB that eventually generated a development roadmap based on market segment needs and trends. This roadmap led ultimately to the launch of the new digital distribution transformer, the TXpert →1-2.

At every step of the TXpert development, design and manufacturing decisions were made with the customer's perspective and expectations regarding engineering, operation, maintenance, etc. firmly in mind.

**Which measurements provide vital information?**

Customers expect distribution transformers to last for 25 to 30 years; any new additions to the product line should do so too. The question then arises as to which parameters, if they were measured directly, would provide vital information about the asset and electrical supply quality – and which sensors best measure these parameters. Given the conservative nature of the industry, only sensors designed for, and used in, harsh environments and with excellent field reliability were considered. The sensors finally picked are from mature industries and are expected to last longer than the transformer itself. The sensors chosen are for top oil temperature, ambient temperature, pressure, moisture, hydrogen, voltage and current, plus two measurements for the oil levels.

**Data capture and analysis**

Every 10 seconds, 14 sensor values of TXpert key operating parameters are recorded and time-stamped. This data is stored fully encrypted for 20 years in appropriately dimensioned memory. Customers reported that data quantities can be overwhelming over time, so advanced analytics integrated directly into the distribution transformer process much of the raw data to produce insights that allow the customers to take suitable action →3.

The current TXpert release conducts two analytics:

- Consumed life of the distribution transformer, which informs the customer how old the transformer is, based on its specific operating conditions.
- Total harmonic distortion (THD), which indicates the quality of the grid around the distribution transformer.



02



03

These two analytics were released first to address the basic needs of most customers. ABB is developing further analytics to address asset health and grid health. Future advanced and predictive analytics aimed at specific customer segments will be released over time via software upgrades. This is the first time in the industry that so many key distribution transformer parameters are recorded simultaneously. ABB is capitalizing on this opportunity by developing artificial intelligence models that analyze the available data and predict failures and operational events →3.

### Connectivity

Almost 80 percent of distribution transformers are not connected to or are even near a communications infrastructure. ABB has included WiFi in TXpert for customers to retrieve data and analytics outputs →4-6. For installations in substations, solar farms, wind farms or wherever communication access points exist, there is a wired Ethernet option to allow customers to use their existing infrastructure. Future expansion of connectivity options such as LTE wireless will appear in future releases. TXpert is not locked to a specific protocol or communication medium, which allows the customer maximum flexibility of

installation anywhere in their electrical grid. TXpert has a Web service user interface that does not require a software installation on customer computers, thus eliminating any burden on the customer's IT organization.

TXpert outputs can be integrated into several software packages, allowing the customer full flexibility to display or integrate data and analytics outputs in a way with which their personnel are familiar.

Cyber security is a key concern for customers. In addition to the stringent ABB guidelines followed during development, testing and validation, three layers of defense were added to support customers:

- The TXpert built-in WiFi is turned off by default and needs to be enabled by an RFID access card. It turns back off after 10 minutes of inactivity.
- Customer computers need to have a valid security certificate to authenticate communication sessions.
- Stored data is encrypted and customers need a decryption key to be able to read the data.



04



05

—  
01 A transformer fitted with TXpert, IEC model, ready to be installed. On top is the communications pod for accessing transformer data and analytics.

—  
02 TXpert is available as ANSI and IEC models based on regional standards.

—  
03 TXpert collects and analyzes a comprehensive set of transformer data. Where appropriate, front-end analysis processes large amounts of raw data to present the operator with actionable intelligence.

—  
04 Engaging TXpert's secure Wi-Fi to access transformer and grid information.

—  
05 An operator views data and analytics from TXpert ANSI model to understand how the transformer and grid are operating.

—  
06 Typical TXpert display.

### Ease of installation

The TXpert hardware is self-powered from the transformer, so there is no additional effort needed during installation and energization. TXpert is like a traditional distribution transformer from the installation and energization perspectives so requires no special treatment from customer organizations such as operation, maintenance, health and safety, communications and IT.

### Customer values

The main focus of TXpert is to support ABB's customer needs by providing vital insights for informed decisions that increase reliability and reduce operating costs.

Each market segment has its own needs, challenges and opportunities. Each customer has their own unique needs.

For utilities:

- TXpert reduces maintenance costs by scheduling inspections more intelligently – ie, customers focus on inspection based on data trends rather than measurements with absolute value at specific moments in time. With remote communications enabled, key operational data and analytics output is available in real time.
- Knowledge of transformer age allows more accurate replacement planning and reduces inventory cost by reducing the need to buy stock units.
- Balancing the load based on transformer and grid conditions allows customers to utilize assets better.
- With remote communications, immediate outage notification is possible, thus reducing downtime and possible financial penalties.
- Revenue protection or energy theft is a concern for some utilities. Energy thieves will connect to the grid at the transformer point. Not only does the utility lose revenue but the transformer can become overloaded and possibly fail. With TXpert, revenues running through the transformer can be calculated and compared against billing meters to make sure they match.

For renewables:

- With the THD value, customers get an indication of the network quality. Further analytics for overall system efficiency, which is crucial in renewable generation, are planned.
- A voltage-profile analytic is planned where customers would get a specific voltage profile for a particular part of the grid during different seasons and at different times, allowing them to take informed decisions rather than the current practice of assumption and simulation. This can eliminate the need for a voltage regulator and allow better grid optimization.

For industry and data centers:

- TXpert reports actual, real-time operating conditions, thus increasing the visibility of uptime and reliability.
- TXpert presents a real asset management and proactive maintenance opportunity based on actual operating conditions where customers can integrate TXpert outputs in their asset management and maintenance programs.

For oil and gas:

- Knowing key operating parameters in real time and taking appropriate and timely action is of great value for oil and gas customers and the operational safety of the transformer.
- Oil level indication and leak detection help protect the environment.

### Product launch

ABB launched ABB Ability TXpert in March 2017 and it has been commercially available worldwide since September 2017. The current release covers transformers from 300 kVA to 10 MVA in the 36 kV class. Coming product releases will expand the range of transformer sizes.

Positive customer experiences are already being reported. For example, one customer reported that TXpert showed their transformers were only 30 percent loaded. The assumption had been that the load would be 80 percent, while in actual fact some transformers in the network were overloaded. With the right data and some simple changes, the customer was able to optimize the grid better and make cost savings by right-sizing the transformers.

ABB's deep domain knowledge and expertise are being further enhanced through edge technologies based on ABB Ability, such as TXpert. As TXpert matures, it will be a catalyst for further refining distribution transformer performance, improving predictability and increasing reliability. ●



SMARTER

# Transformer asset management – do more with less

Market pressures lead companies to reduce budgets for transformer maintenance and replacement – and ask more from existing assets. The ABB Ability Transformer Intelligence portfolio helps reduce transformer maintenance costs by optimizing transformer asset management and supporting units in service.

**Lony Tehini**  
ABB Transformer  
Remanufacturing and  
Engineering Services  
Montreal, Canada

Lony.tehini@ca.abb.com

**Pierre Lorin**  
ABB Transformer  
Remanufacturing and  
Engineering Services  
Geneva, Switzerland

Pierre.lorin@ch.abb.com

**Tucker Reed**  
ABB Transformer  
Remanufacturing and  
Engineering Services  
St Louis, MO, United States

tucker.b.reed@us.abb.com

With an average age in industrial plants of 30 years and in utilities of 40 years, the world's transformer fleet is aging – and is incurring associated increasing replacement and repair costs, and risk of failure. The economic pressures of deregulated and competitive markets, and the tendency to overload transformers, only exacerbates matters. Many transformers are now also operated beyond their recommended life span in order to smooth investment peaks.

These conditions make it imperative to adopt life-prolonging measures and to optimize transformer maintenance.

One significant maintenance optimization strategy is to replace simple time-based maintenance that mitigates risk by doing everything, every year, for all transformers, with a more sophisticated condition-based maintenance strategy – ie, focusing maintenance on high-risk transformers. It is estimated that a life extension of 5 to 15 years can be achieved with properly focused preventive maintenance programs. The ABB Ability Transformer Intelligence portfolio supports this strategy shift by focusing on three elements: monitoring hardware, interpretation software and expert service →1.





01

— 01 ABB offers transformer monitoring systems that help reduce repair, maintenance and running costs.

— 02 Key parameter monitoring gives early warning of faults developing in the main tank or accessories, allowing an operator to evaluate the severity of the situation.

### The benefits of condition assessment

On a long-term and strategic level, a condition assessment study gives top management a clear picture of the maintenance and renewal investments that are required over the next 20 to 30 years to provide asset reliability and availability. This type of insight provides solid information to compare different asset management strategies and choose the approach that best supports the overall technical and financial strategy of the company.

In the medium term, a condition assessment gives asset managers the input necessary to make the best use of maintenance or replacement budgets. Funds can be allocated to units that show the best return on investment while reducing technical and environmental operation risks.

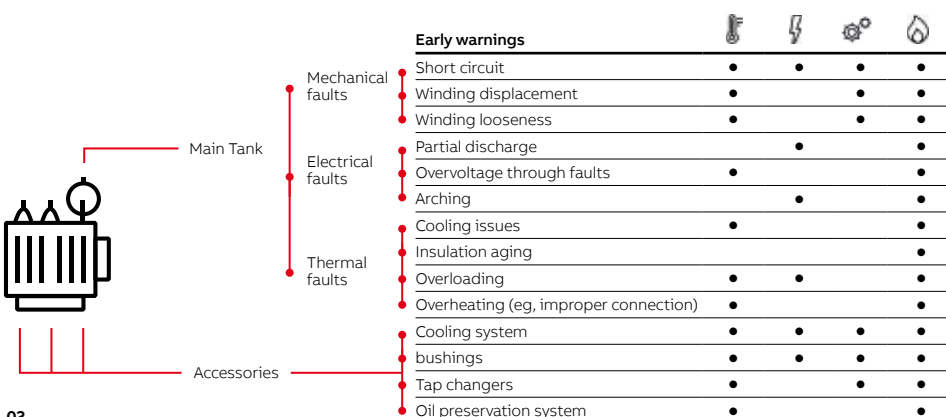

### Monitored parameters:

- Temperature
- Electrical
- Mechanical
- Chemical

02



03

And in the short term, the assessment can tell the maintenance manager how to apply the maintenance actions that secure the asset reliability required.

**Plug and play devices to unlock even more value from the transformer**

A CIGRE study has shown that transformer monitoring can reduce the risk of catastrophic failures by 50 percent [1] and that early problem detection can reduce repair costs by 75 percent and loss of revenue by 60 percent. Furthermore, annual cost savings can amount to 2 percent of the price of a new transformer – ie, approximately \$40,000 to \$80,000 [2].

Transformer monitoring, then, makes good financial sense.

Transformer monitoring relies on temperature, electrical, mechanical and chemical sensors →2. ABB offers multiple sensors for these parameters, including the CoreSense™ family for dissolved gas analysis (DGA). CoreSense provides a nonintrusive, maintenance-free and easy-to-install solution that flags a potential fault with hydrogen measurement. Deeper analysis can be performed with the multigas version, the CoreSense M10 →3.

—  
03 CoreSense M10 is the ultimate transformer DGA diagnostic tool. It monitors the transformer condition by observing moisture levels and nine different gases. It can be provided with a local (ie, non-cloud) version of ABB Ability Ellipse, ABB's asset management solution.

—  
04 Historical data along with real-time data analytics provide an asset probability of failure along with maintenance recommendations.

**CoreSense M10 multigas analyzer**

The CoreSense M10 utilizes Fourier-transform infrared (FTIR) technology combined with solid-state hydrogen and moisture sensors to measure moisture and nine gases: hydrogen (H<sub>2</sub>), methane (CH<sub>4</sub>), acetylene (C<sub>2</sub>H<sub>2</sub>), ethylene (C<sub>2</sub>H<sub>4</sub>), ethane (C<sub>2</sub>H<sub>6</sub>), propene (C<sub>3</sub>H<sub>6</sub>), propane (C<sub>3</sub>H<sub>8</sub>), carbon monoxide (CO) and carbon dioxide (CO<sub>2</sub>). The CoreSense M10 is also provided with a local version of Ellipse, ABB's asset management solution. Ellipse employs a number of algorithms sequentially to establish if there is any abnormality and, if there is, to make recommendations for action →4.

**Tough and accurate enough for space**

The gas-measuring FTIR module in the CoreSense M10 is based on the same ABB technology that is deployed in satellites to analyze greenhouse gases and meteorology in the Earth's atmosphere. The first unit was launched more than 15 years ago and is still in service today. This technology is sought after for its outstanding reliability, accuracy and stability in harsh environments. In addition, the calibration-free nature of the technology provides significant savings in maintenance and replacement costs.

On earth, ABB's FTIR is also used in other applications such as refineries, semiconductor factories and chemical plants to measure chemical compounds in liquids because it can meet up to 99 percent reliability and provide stable measurements over extended periods of time, allowing identification of long-term trends.

Applying proven and robust FTIR technology to transformers assures that the DGA sensor is accurate, reliable and calibration-free.

**ABB Ability Ellipse Asset Performance Management**

In the context of transformer health management, a major challenge for many industrial and utility customers is to analyze and keep track of the data generated by both online and offline measurements. Often, data exists in isolation and its interpretation relies heavily on transformer experts, many of whom are soon to retire.

ABB's solution to these issues is ABB Ability Ellipse Asset Performance Management (APM). APM combines decades of subject-matter expertise in transformer manufacturing and maintenance with historical and real-time data analysis from transformer sensors. This continuous health and performance insight prevents critical asset failures while optimizing asset life cycle costs [3]. Each asset is also categorized according to its current health condition and expected life.

With all this actionable intelligence, utilities can optimize the operational and maintenance spend to maximize the capabilities of their assets and budgets and build business cases for repair/replace decisions.

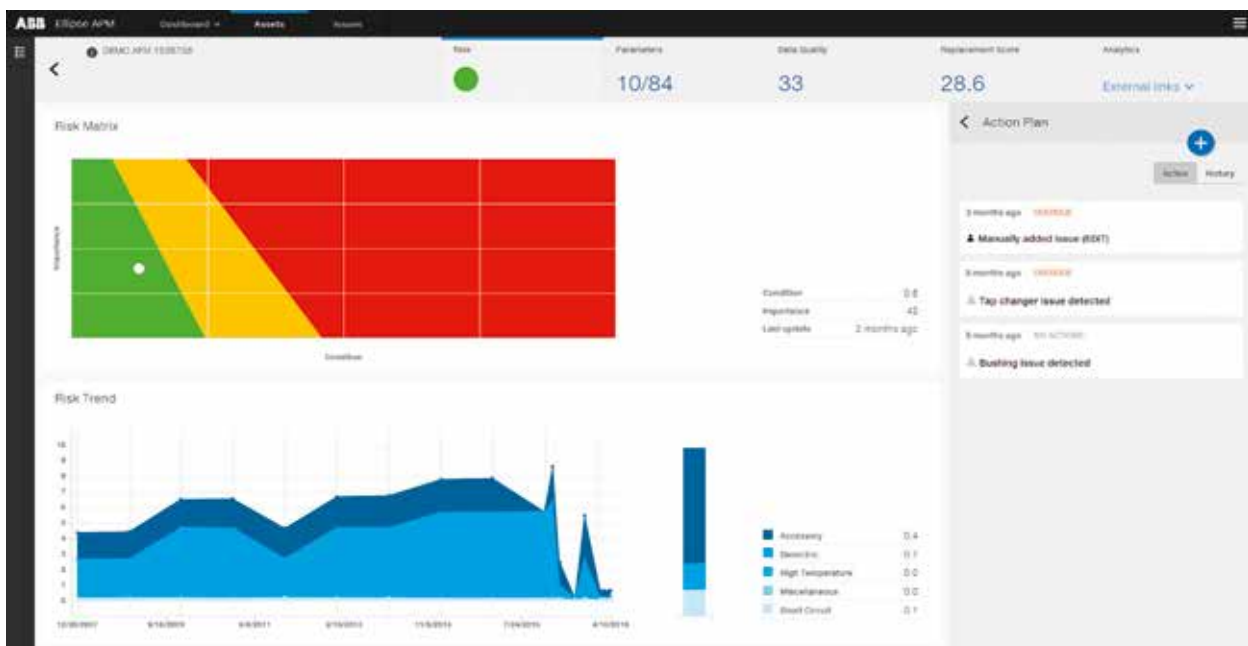

—  
05 TXplore and images captured during inspections.

05a The TXplore inspection “submarine” is lowered into a tank.

05b The robot inspecting tap changer contacts.

05c A still from the robot’s inspection video showing a flashover on a winding.

—  
06 On-site repair and testing – retrofit of a substation transformer with ester oil.

### ABB specialists interpret data from the transformer and provide services

Once APM triggers an alarm or recommends an action, for specific and complex cases, ABB experts can help make good use of the data collected by online monitoring sensors, as well as the output of asset management software, to analyze the condition of certain transformers or transformer fleets. The combination of this data with the design data, the information in ABB’s installed base system, the results of oil analysis, condition assessments and the maintenance history provides ABB with a 360-degree view of a transformer fleet. This insight plays a pivotal role for ABB in the condition assessment process [4].

ABB has access to design knowledge worldwide and original designs for more than 30 legacy brands. Also, all new ABB transformers are built using the same design concept, which incorporates standardized, service-proven components, thus ensuring an efficient service out in the field. Expert assessment is not only important for minimizing the risk of failure and extending lifetime but also for providing valuable information for initiating maintenance or repair work should a problem occur, resulting in shorter downtimes.

### Historical review

ABB has a plethora of data on the transformer installed base. This data is continuously updated, eg, current owner details and history. The system provides an important basis for the proactive detection of problems. For example, one analysis revealed a potential cooler problem in about 700 transformers in the installed base. The search focused on 10 to 600 MVA transformers that were over 20 years old and had oil- and water-type coolers. Some had failed due to leakages in these cooling systems and one such failure resulted in significant revenue loss for the operator. Using installed base data, operators were contacted proactively and advised to carry out regular checks.

### Training and consultancy

ABB experts also provide on-site or off-site training in transformer technical specifications, design, manufacturing, quality and factory acceptance tests, testing, diagnosis, online monitoring and asset management systems as well as spare parts, maintenance, repair, upgrade and replacement – including safety, environmental aspects and economics.

### Inspection robot

Troubleshooting sometimes involves draining the transformer oil so a specialist can gain access. This procedure involves a significant outage, risks and expense. However, ABB has now developed TXplore – a remotely controlled inspection “submarine” – to do this job →5. This automated inspection tool eliminates the need to put a human at risk and expose the transformer’s internal structure to external contaminants.



05a



05b



05c



06

#### References

[1] "Economics of transformer management," CIGRE Technical Brochure 248, June 2004.

[2] Cheim L. et al., "Transformer Reliability Taking Predictive Maintenance Program to the Next Level," CIGRE Study Committee A2 COLLOQUIUM, October 2017

[3] Boss P. et al., "Economical aspects and practical experiences of power transformer online monitoring," Report 12-202, CIGRE 2000.

[4] Lorin P. "Forever young (long-lasting transformers)," IET Power Engineer, 19(2), pp. 18–21, April/May 2005.

[5] L. Eklund et al., "On-site transformation: TrafoSiteRepair™ combines the old with the new to improve power transformer availability," ABB Review 4/2007, pp. 45–48.

[6] P. Lorin et al., "Sustainable and available: Enhancing performance and reducing environmental impact of existing transformer fleets," ABB Review Special Report: Transformers, pp. 64–68 April 2012.

#### On-site repair

ABB's on-site repair service [5] speeds up transformer repair and has, over the years, saved users millions of dollars by reducing downtime by four or more weeks. The on-site repair is achieved by bringing the transformer factory setup to the work site, which allows for any scope of work to be carried out, from refurbishment to full winding replacement – all performed to the same quality standards as in the ABB workshop →6. Such repairs have been carried out worldwide on over 500 transformers, including ultrahigh-voltage transformers, converter transformers, industrial units and shunt reactors.

Due to significant progress in power electronics, ABB's compact test systems can now perform most high-voltage tests on site, including applied and induced voltage, heat run and impulse tests.

#### Eco-friendly retrofit

The environmental impact of new plant or retrofits can be reduced by employing ABB eco-friendly solutions that combine component reuse, innovative materials (natural and synthetic ester oils, aramid fibers, amorphous steel) and modern technologies (dry bushings, vacuum tap changers, active noise control) [6].

These solutions reduce the risk of fire and pollution, minimize losses and noise, allow material recycling and reduce maintenance. They also allow capital investments to be deferred while providing extra overload capacity to cope with growing power demands.

The ABB Ability Transformer Intelligence portfolio is helping transformer operators around the world cope with ever-increasing commercial and regulatory constraints by allowing them to closely monitor equipment condition, analyze and interpret results to produce actionable intelligence and benefit from the long experience ABB has built up since it launched its first transformer over a century ago. ●

GREENER

# Environment comes first with ABB's oil-free transformers

Oil-filled transformers are the predominate transformer technology in use today. Nonetheless, hazardous risks to humans and the environment still exist such as fire and spills. ABB continues to develop oil-free transformers to eliminate these potentially catastrophic events.



**Joel Kern**  
ABB Transformers  
Raleigh, NC, United States

[joel.a.kern@us.abb.com](mailto:joel.a.kern@us.abb.com)

Increasing environmental awareness and demand for electric energy coupled with modern urbanization trends have led ABB to develop innovative products for the supply, generation and transmission of power. Transformers are critical components in energy grid systems and are increasingly required to operate at reduced risk to humans and eco-sensitive environments.

Transformers, which traditionally use mineral oil for insulation and cooling, allow energy to be transported from the production source to the location where power is needed. Increasingly located in metropolitan areas →1 and near environmentally sensitive areas like harbors, transformers that use oil can pose safety and environmental challenges and generate additional long term costs. Since the late 1980's ABB has sought alternative liquids and materials to reduce these risks. Oil-free transformers have continued to be a viable alternative in a growing number of niche markets, where ecology and safety drive choice.

#### **Advantages of oil-filled transformers**

Currently, oil-filled and oil-free (dry-type) transformers are available; the obvious difference is the presence or absence of oil. Oil has ideal dielectric and cooling properties for use in transformers. Oil-free transformers rely solely on solid insulation ie, polyester films, aramid fibers and epoxies as the dielectric material and ambient air for cooling.

Though the dielectric capabilities of solid insulations are comparable to that of oil [2], transformer oils are orders of magnitude better at cooling than ambient air. This allows oil-filled transformers to be smaller, lighter, and produce lower noise levels than dry-type transformers of equivalent power ratings. These advantages have made oil-filled transformers the primary technology for today's globally installed transformer market.





01

—  
01 Crowded urban areas, like Dubai, are ideal locations for dry-type transformers.

Mineral oil for transformer use was successfully introduced in the 1970's to replace the polychlorinated biphenyls (PCB) that were progressively banned due to their hazardous impact on human and environmental health. Despite the extensive safety history of oil-filled transformers, mineral oil has a relatively low flash point (170°C); a property that can result in catastrophic fires and explosive failures under rare conditions – causing concerns.

During the late 1980's ester oils, or seed oils, were investigated as an alternative fluid for transformers to diminish these risks. Natural esters have a higher flash point (330-360°C) than mineral oils; this allows the transformer to operate at higher temperature

rises (up to a maximum 75°C rise) and greatly increases their fire safety ratings. Further, ester oils are renewable, non-bio-accumulating and non-toxic and are potentially biodegradable.

#### **Transformer oil risks**

Despite the risk mitigation achieved by using ester oil instead of mineral oil, measurable risks still exist: all oils have flashpoints, and therefore pose a fire or explosion risk; and all oils can leak and present a risk to humans and the environment. As previously stated, mineral-oil and esters, both synthetic and natural oils, are characterized by flash points of 170°C and 330-360°C, respectively [1].



02

Design features are implemented to control transformer rise temperatures to ensure that oil flash points are never exceeded under normal operating conditions. Nonetheless, some electrical events eg, short circuits or internal arcing faults, can push internal temperatures to values above the oil flashpoint →2. Though rare, a potential catastrophic failure of the transformer is by no means a negligible risk.

Furthermore, if a surrounding forest or building catches fire and reaches an oil-filled transformer, the temperatures within will surpass the flash point of any oil, thereby exacerbating conditions and possibly augmenting the fire to the point of uncontrollability. Despite extreme measures taken to extinguish transformer fires they can burn for hours, or even days, emitting smoke and toxic or corrosive gases into the air, and dumping hazardous debris from the combustion or fire extinguishing process into the surroundings [3].

In the event of a low impedance fault, an internal arcing can cause temperatures to reach a few thousand °C. The potential energy released by such an event, for large transformers, can reach 147 MJ. Such high temperatures will vaporize the oil, thereby producing combustible gas, which in small amounts is harmless. If, however, the structures are left unattended and pressure builds up, the tank may pose an explosion risk. Mechanical and electrification methods are typically executed to mitigate this risk eg, oil-breathers, pressure relief valves, and the addition of equipment to regularly monitor the dissolved gas are installed. [4] Consequently, transformer explosions are uncommon as evidenced by long-term studies in which the probability of failure for a fleet of 765 kV transformers was 1.21 percent; and of these failures only 0.14 percent resulted in fires [4].

Despite precautions to prevent internal arcing, a residual risk remains. Approximately 54 percent of transformer fires are due to the rupture of tanks or bushing turrets, which can result in oil spills. Mineral oil is non-biodegradable and



03

environmentally hazardous; any leakage must be treated comprehensively and quickly. Ester oils are fully biodegradable when unused [5].

Small spills (< few liters) can be consumed by natural organisms over a period of 28 days [6]. Larger spills however, can cause oversaturation and greatly prolong the natural biodegradability of the oil.

A two MVA transformer requires more than 2000 liters of oil to operate properly. A spill of this size, typically the result of rupture to corroded tanks, accidental structural damage, or theft due to copper harvesting, could be devastating to the surrounding environment. Oil that enters waterways poses an immediate threat to nature and wildlife and to water meant for human consumption. Huge financial costs can ensue for cleanup and re-establishment of operations. This burden is often magnified by a risk to corporate reputation. Obviously, the oil must be removed immediately to avoid all further negative outcomes [7].

All transformer oils become contaminated during operation, thus reducing biodegradability. Major environmental agency regulations do not differentiate between ester or mineral oil in their regulations concerning the handling, spillage treatment, or disposal of these oils in regard to environmental or human health impact. Either at the end of life or following carbon saturation, ester oils are replaced and, like mineral oil, must be treated as a bio-sensitive material.

#### **Dry-type transformers**

In addition to mechanical and electrical design features, surrounding protective devices such as fast-acting fire suppression systems and oil containment structures →3 reduce hazard potential. And yet the most economical solution would be to place an oil-filled transformer, with minimum protection, in a location where it would not pose a threat. However, power needs often require transformers to be situated near densely populated areas, or in the vicinity of waterways or other sensitive eco-systems. For this reason,

—  
02 ABB's ester oil power transformer with surrounding containment is shown.

—  
03 72 kV dry-type transformer with dry-type on-load tap-changer.

—  
04 Wind farms located in eco-sensitive coastal regions benefit from dry-type transformers.

dry-type transformers that use alternative dielectric and coolant materials are primarily installed in these areas.

All dry-type transformer components are in solid form; they do not have flash points, nor do they require bushings. Thus, major causes of fire and spillage are eliminated. The ability to operate at high temperatures gives these transformers increased durability and overload capacity. Furthermore, by minimizing the impact on the environment and eliminating the risk of fire, total costs can also be reduced. Consequently, dry-type transformers are increasingly used in metropolitan areas to step down three-phase medium-voltage to low-voltage for power distribution.

There are a few limited applications in which water may be used to cool the air or the conductor itself inside a dry-type transformer. These applications include installations where cold-water loops are used to cool other equipment, eg, hydro generation, marine vessels and offshore wind parks. All other applications that use dry-type transformers employ only solid components and are self-extinguishing; in other words, in case of an arcing failure, no fire will be sustained once the arc has dissipated. In addition, the majority of insulating components can be recycled; these materials can be placed in inert landfills making waste management effortless and cost-effective.

The predominant disadvantage of using dry-type transformers is the reduced cooling capacity that limits the achievable power and voltage ratings for oil-free technologies. Also, they are typically larger and heavier than oil-filled units. Consequently, dry-type power transformers have been traditionally used for power transmission and distribution with a rated power below 15 MVA and voltage less than 36 kV.

The decision of whether or not to use dry-type transformers depends on the environmental and safety considerations and power needs. Nevertheless, cost is always a factor and dry-type transformers are cost-effective. The total cost of ownership, which includes the total cost of installation and the additional costs of providing protection against fire and leakage, translate to lower civil works and building code requirements (no containment, fire suppression or fire rated building structures etc. are required).

Overall, dry-type technologies are the best transformer choice for specific markets where ecology and safety are paramount concerns. ABB's oil-free transformers provide the best solution for customers who operate in sensitive areas eg, urban centers, public buildings, waterways, harbors, offshore wind farms and railways among others →4. Nevertheless, for large power and transmission voltage classes, oil-filled transformers are still today's only possible choice.

04



—  
05 ABB's dry type power transformer HiDry for sub-transmission up to 145 kV/63 MVA.

#### References

- [1] B. Zimmerman, "Consideration of Ester-Based Oils as Replacements of Transformer Mineral Oil," PGE, Nov. 1 2014.  
 [2] L.I. Berger, "Dielectric Strength of Insulating Materials," 2018 www.chemistry.mdama.ch  
 [3] E. Csanyi, "What happens when a transformer fire occurs in a substation," EEP, Aug. 12th, 2016. www.electrical-engineering-portal.com  
 [4] G. Frimpong, "Cause of Hydrogen Gas in Transformers," T&D World, Mar. 10, 2014. www.tdworld.com  
 [5] Midel "Fluids Comparison," 2018. www.midel.com  
 [6] "Envirotemp™ FR3™ Fluid," Cargill, 2018. www.cargill.com  
 [7] "Vegetable Oils and Animal Fats," US Environmental Protection Agency, 2018. www.epa.gov  
 [8] M. R. Ayuso, "Safe and Ecological: HiDry type Transformers for Subtransmission," ABB, 2017.

### The future is bright for dry-type transformers

The need to improve environmental and personal safety, motivates ABB to continually expand the limits of dry-type technologies. In 2010, ABB increased the power and voltage limit of dry-type transformers to sub-transmission up to 72 kV / 63 MVA →5. Today, there are dozens of installations around the world that benefit from these increased ratings in utility for urban power transmission and rail traction infrastructure. Global trends in urbanization and environmental awareness have incited ABB to aim for superior results in dry transformer technology. In 2016, ABB successfully tested a prototype of a dry-type transformer for sub-transmission up to 145 kV / 62 MVA, thereby meeting safety standards and ensuring environmental integrity. Such power systems feed higher voltage directly to the main load centers; higher power is achieved at reduced distribution loss. The current challenge is to develop an accompanying dry-type on-load tap-changer – a necessity for higher voltage classes [8].

ABB is also investigating new ways to increase the monitoring capacity of dry-type transformers to be more like that of existing oil-filled units.

In 2018, ABB is scheduled to release the ABB Ability TXpert™ digital dry-type transformer. Using the ABB Ability™ platform technology, this transformer will have increased capabilities to monitor the power quality at the unit, provide advanced warning of any abnormal system occurrences, monitor fan function and control, and provide flood water damage alerts. These features will allow users to obtain a more accurate understanding of the transformer life cycle status and prevent unnecessary outages.

Overall, there are millions of dry-type transformers in operation worldwide. Currently, ABB produces more than 40,000 units each year and offers its customers, oil-free transformer solutions with primary voltages through 72.5 kV built in accordance with major standards such as IEC and ANSI. The expansion of ABB's transformer portfolio to include a variety of dry-type transformers provides customers with innovative solutions to meet their unique power needs without relinquishing environmental or human safety. ●



---

GREENER

# Eco-friendly ester liquid transformer designs

Ester liquids have been used in transformers for insulation and cooling purposes for over 20 years. These liquids greatly reduce environmental impact and significantly mitigate spillage and fire risks. Recent experience underlines the benefits of using ester liquids instead of traditional mineral oils.

**George Frimpong**  
ABB Power Grids,  
Transformers  
Raleigh, NC, United States

george.k.frimpong@  
us.abb.com

**Jan Hajek**  
ABB Power Technologies  
AB, Power Transformers  
Ludvika, Sweden

jan.hajek@se.abb.com

**Krzysztof Kulasek**  
ABB Power Grids  
Montreal, Canada

krzysztof.h.kulasek@  
ca.abb.com

Since the 1990s, ester liquids have been gaining acceptance for transformer insulation and cooling →1, with application voltages now reaching 420 k. This shift from traditional mineral oils can be attributed to growing environmental awareness and the need to address the risks of tank rupture and fire, especially in crucial locations. Ester liquids lend themselves as a natural and safe, and

almost obvious, solution, and they have related benefits such as smaller substation footprint and simplified oil containment design [1-2]. The 10 to 15 percent extra cost of ester-filled transformers is more than compensated for by the benefits it brings.

01



Parameter	Unit	Envirotemp FR3	MIDEL 7131	Mineral oil
Density at 20 °C	g/ml	0.92	0.97	0.87
Kinematic viscosity at 100 °C	mm <sup>2</sup> /s	8	5.25	3
Kinematic viscosity at 40 °C	mm <sup>2</sup> /s	33	29	12
Kinematic viscosity at 0 °C	mm <sup>2</sup> /s	190	280	76
Thermal conductivity at 20 °C	W/m K	0.167	0.144	0.120
Pour point	°C	-21	-60	-60
Flash point	°C	315	275	160
Fire point	°C	355	317 ± 5	170
Relative permittivity	-	3.2	3.2	2.2
Classification of flammability	-	K	K	O
Breakdown voltage IEC 60159 2.5 mm	kV	73	> 75	> 70
Dielectric dissipation factor, Tan $\sigma$ at 90 °C 50 Hz	-	0.005	< 0.008	< 0.002
Moisture saturation at ambient temperature	ppm	1,000	2,700	55

02

01 As transformer insulation and coolants, ester liquids have many advantages over traditional oils.

02 Comparison of different liquid characteristics.

03 Moisture evolution in cellulose impregnated with natural ester and mineral oil at 130 °C.

In recent years, much progress has been made in ester-filled transformer applications, especially in the realms of:

- Eco-efficiency and safety
- Life extension – slower aging of insulation and longer lifetime
- Overloadability – flexibility in handling the load or minimizing footprint for mobility

**Eco-efficiency and safety**

The major safety and environmental concerns of transformers are catastrophic failure and oil spill. Small leaks can occur due to handling errors (eg, overfilling) but more serious leakages happen when a unit ruptures. Leakages can also lead to fires: of the around 1 percent of failures that necessitate major repair or scrapping [3], one-tenth result in a transformer fire.

This seemingly low incidence rate conceals a significant risk as, on top of danger to workers and reputational loss, the average cost of replacement, clean-up and lost revenue is about \$3 million, and individual cases have been known to incur costs of up to \$86 million [4].

In any of the abovementioned situations, cooling and insulation fluid biodegradability, and high flash and fire point, improve operator safety, while reducing the impact and cost of cleanup.

Natural ester liquids are classified (see, eg, standard EC 61039) as non-toxic and readily biodegradable substances. Therefore, spills are characterized as nonhazardous.

If a transformer protection system is slow to react to a low-impedance fault, the high-energy internal arc generated can produce gases that lead to overpressure and tank rupture, thus allowing the ingress of oxygen to create a fire-prone environment [2]. For such failures, the most important parameters of the liquid used are its flash and fire point values. Compared with mineral oil, ester liquids have much higher flash and fire point temperatures →2. They meet the US National Electric Code (NEC) definition of less flammable dielectric liquids and are recognized as such by both FM Global and Underwriters Laboratories (UL), both independent product safety certification organizations. The byproducts of the combustion of natural esters are much less toxic than those of mineral oils, further reducing their overall impact on the environment.

Hydro plants that are located close to sensitive waters, for example, can benefit from the reduced environmental threat provided by ester-filled transformers.

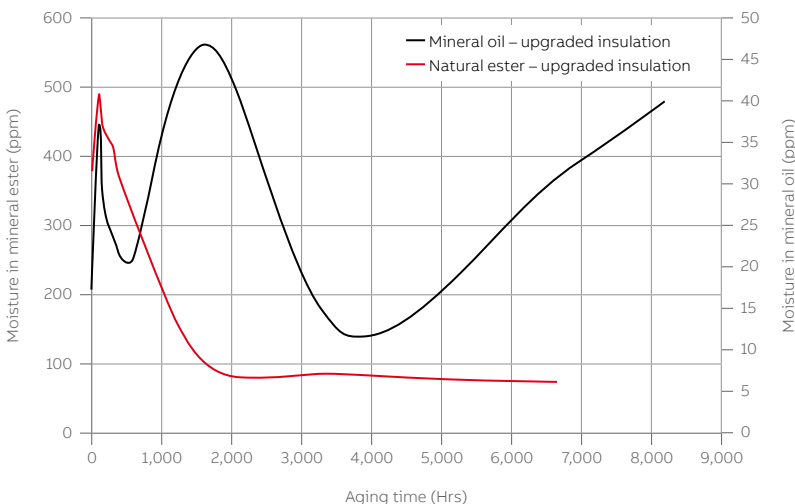

03

	IEEE C57.154-2012		IEC60076-14	
	Mineral oil	Ester fluid	Mineral oil†	Ester fluid
<b>Maximum continuous temperature rise limits for transformers with high-temperature insulation systems</b>				
Minimum required high-temperature solid insulation thermal class	120	140	120	140
Top liquid temperature rise, (°C)	65	90	60	90
Average winding temperature rise, (°C)	65	85	75	95
Hottest spot temperature rise, (°C)	80	100	90	110
<b>Suggested maximum overload limits for transformers with high-temperature insulation systems</b>				
Maximum top liquid temperature with normal life expectancy (°C)	105	130	105	130
Maximum top liquid temperature with loading above nameplate rating (°C)	110	140	115	140
Maximum solid insulation hottest spot temperature with normal life expectancy (°C)	120	140	115	140
Maximum solid insulation hottest spot temperature with planned loading beyond nameplate rating (°C)	130	150	130	150
Maximum solid insulation hottest spot temperature with long-term emergency loading (°C)	140	160	140	160

†For semi-hybrid insulation winding

04

— 04 Maximum continuous temperature rise limits and suggested overload temperature limits for 120- and 140-class insulated transformers.

— 05 138 kV compact mobile substation filled with a natural ester insulating liquid, in transit.

Between 2002 and 2016, ABB delivered 14 transformers with powers ranging from 16 to 40 MVA to the Warmian-Masurian region of Poland, well-known for its many nature reserves and lakes, and for being part of the EU Natura 2000 project. The choice of synthetic ester liquid Midel 7131 contributed to the protection of the landscape by obviating the need for oil containment and fire suppression systems.

#### Life extension – slower aging of insulation and longer lifetime

The lifetime of a power transformer is defined by the decay rate of its cellulose insulation. This decay increases with increasing oxygen and water content in the paper and the surrounding insulating medium.

Insulation systems composed of ester liquids and cellulose materials have been shown to operate with lower moisture content in the insulation system and endure higher temperatures than those composed of mineral oil and cellulose materials, making them an ideal choice [5].

There are three factors that contribute to the lower aging rate and longer lifetime of ester-filled transformers:

- The moisture content in the mineral-oil-filled system increases with time, while that of the ester-filled system declines. An ester-filled cellulose insulation system operates with lower cellulose insulation moisture content than one filled with mineral oil →3.
- The solubility of water in ester liquids is several times higher than in mineral oil at typical transformer operating temperatures. This means more water is drawn out of the paper into the ester liquid.
- Cellulose polymers change when aged in natural ester liquids. The chemical reaction of water generated during the cellulose aging process with natural esters produces free fatty acids that attach to the cellulose structure through a reaction called trans-esterification, thus forming a barrier to water ingress, leading to a decline in the rate of deterioration of the cellulose insulation [5].

The practical result of the combined effect of all these phenomena is that cellulose insulation has a 20 °C thermal advantage when aged in ester liquids [5-6]. Specifically, for the same life expectancy, cellulose impregnated with ester liquids can be designed with a 20 °C higher hottest spot temperature than one with mineral oil.



05

—  
06 200 MVA/420 kV  
liquid-ester unit.

#### References

- [1] J. C. Mendes et al., "Oiled and ready to go: Advanced application of ABB BIOTEMP® vegetable oil in a HV power transformer," ABB Review 3/2007, pp. 53-57.
- [2] G. Frimpong et al., "Transformers transformed: Using vegetable oil as an insulating fluid reduces transformer fire risk," ABB Review 2/2012.
- [3] "Guide for Transformer Fire Safety Practices," Cigre Report 537, June 2013.
- [4] William H. Bartley, "Analysis of Transformer Failures," The Hartford Steam Boiler Inspection & Insurance Co. International Association of Engineering Insurers 36th Annual Conference – Stockholm, 2003.
- [5] G. K. Frimpong, et al., "A Survey of Aging Characteristic of Cellulose Insulation in Natural Ester and Mineral Oil," IEEE Electrical Insulation Magazine, Vol. 27, No. 5, pp. 36-48, 2011.
- [6] IEEE C57.154-2012, "Standard for the Design, Testing, and Application of Liquid-Immersed Distribution, Power, and Regulating Transformers Using High-Temperature Insulation Systems and Operating at Elevated Temperatures."
- [7] J. Hajek et al., "Considerations for the Design, Manufacture, and Retro-filling of Power Transformers with High Fire Point, Biodegradable Ester Fluids," CIGRE Paris 2012.

### Overloadability – flexibility in load handling or minimizing footprint for mobility.

In a typical transformer design, the insulation system limits the highest temperature at which the conductors and metallic parts can operate. For a conventional system with mineral oil and thermally upgraded cellulose insulation, the highest temperature allowed is 105 °C for the oil and 120 °C for the conductor →4. Higher MVA supplied for the same footprint would mean higher temperatures in the transformer, which shortens its lifetime. To achieve higher MVA in the same or smaller footprint, the transformer would need to be designed using high-temperature insulation materials. Such materials, like ester liquids and ester-liquid impregnated cellulose, allow operation at higher temperatures without appreciable deterioration of the insulation system. Also, there should be no additional risk of failure from operating the transformer at higher temperatures.

For transformers insulated with thermally upgraded cellulose and ester liquid, the limit for the top oil temperature is 130 °C and the hotspot temperature under normal cyclical loading can be as high as 140 °C. The only limiting factors will be transformer components such as tap changers or bushings, which will also have to sustain much higher temperatures.

Consequently, low- and medium-power transformers with ester liquids can be overloaded continuously by an average of 25 percent without negative impact on their lifetime. In combination with Aramid insulation – a high-temperature insulation paper material that can be used up to 200 °C – the overloadability of such transformers can be even higher without appreciable loss of life. This combination leads to the ultimate value proposition for end users: transformers with the same performance but with a much smaller footprint.

For example, instead of using two 30 MVA conventional transformers to meet a station capacity of 60 MVA, two 20 MVA ester liquid insulated transformers (with their additional overload capability) could be applied to meet the load and contingency requirements for the station. Also, these lower-rated transformers use less core steel and therefore will have lower no-load losses. The higher thermal performance of ester-liquid-insulated transformers can be used to advantage in mobile transformer applications →5, offshore applications and industrial production applications.

#### A global trend

In comparison to mineral oil, ester liquids have cost, operation and safety advantages in specific applications. They require careful design, production process considerations and compatible material and accessories selection [7]. When such considerations are made, ester liquids can be used in high- voltage power transformers →6. ABB has delivered more than 200 ester-filled power transformers.

Globally, environmental requirements are increasingly part of the business decision process. One major goal is to retain as much value as possible from resources, products, parts and materials to create a system that allows for long life, optimal reuse, refurbishment, remanufacturing and recycling. ABB's eco-efficient power transformers can help do this. ●



---

GREENER

# Driving down energy losses in transformers

With some 5 percent of global electrical energy being consumed by transformer losses, energy efficiency has become one of the main drivers of transformer technology evolution and regulation.

01

**Miguel Cuesto**  
**Miguel Oliva**  
ABB Transformers  
Cordoba, Spain

miguel.cuesto@es.abb.com  
miguel.oliva@es.abb.com

**Kai Pollari**  
ABB Transformers  
Vaasa, Finland

kai.pollari@fi.abb.com



Energy demand and availability are intertwined with a nation’s economic growth and welfare. This symbiosis is reflected in many countries by the relentless escalation in energy requirements driven by thriving economic activity and increasing population. At present, electric power satisfies a large proportion of this demand and new factors, such as electric vehicles and renewable energy sources, are expected to increase this share.

In this context, electrical equipment efficiency plays a vital role, especially in transformers, where losses account for some 5 percent of global consumption – more than the electricity demand of the continent of Africa.

ABB is at the forefront of the energy efficiency revolution and provides technologies right along the electrical energy value chain that typically pay for themselves within a few years through lower energy costs. Transformers are key links in this energy value chain.

In fact, energy efficiency has become one of the main drivers of transformer technology evolution and regulation. For example, a major initiative being implemented by major economies in support of a more efficient use of energy is the so-called minimum energy performance standard (MEPS) for transformers →2-3. Transformer MEPSs differ by country and region and have to be normalized to provide a comparison →3. In 2017, The first global reference document for transformer efficiency and related metrics was published (IEC 60076-20 TS).

**Advantages of energy-efficient transformers**

Efficiency improvements in transformers can lead to significant energy and emissions savings, while bringing net economic benefits because the marginal cost is spread over the lifetime of the equipment. Energy-efficient transformers also provide extra capacity, potentially lower electricity bills, reduce peak loading and related pollution at power plants, and enhance energy security and reliability.

ABB pursues many technical solutions for enhancing transformer energy efficiency. These range from better core construction techniques to lower-loss core and conductor materials. Winding design and utilization of magnetic shields and other solutions to decrease load losses can also have a considerable impact. Efficiency also comes from how the system is configured and how products, technology and knowledge can be combined to deliver a stronger and smarter grid – for example, by transmitting energy more efficiently by using higher voltages, both AC and DC, or by using products that make more efficient use of the network, such as:

- Better interconnections.
- FACTS (Flexible Alternating Current Transmission Systems).
- Reactors or phase-shifting transformers.
- Transformers specifically designed to simplify renewable energy generation and integration: solar and wind transformers; collector transformers, and AC and HVDC units for local connection to the grid.

New transformer technology and materials, and physical modeling and simulations can also deliver designs that lower losses or give the same losses but with less material or improved transportability.



01 With rising concern over climate change, it is more important than ever to use energy efficiently. As 5 percent of global energy is consumed by losses in transformers, any measures that reduce these losses will have a major positive impact on the world's energy consumption.

02 Examples of current initiatives for energy efficiency.

03 Example of MEPS (normalized) for three-phase liquid-filled transformers [1]. Efficiency at 50 percent load, using the IEC definition of rating and efficiency.

04 Example of the use of 3-D tools for optimized use of magnetic shunts to reduce tank wall losses. Green areas show where leakage flux is successfully collected; blue shows where it is not.

04a Large blue areas indicate this design is poor at leakage flux collection, so there will be high loss in the tank.

04b The prevalence of green indicates high collection of leakage flux and lower losses in the tank.

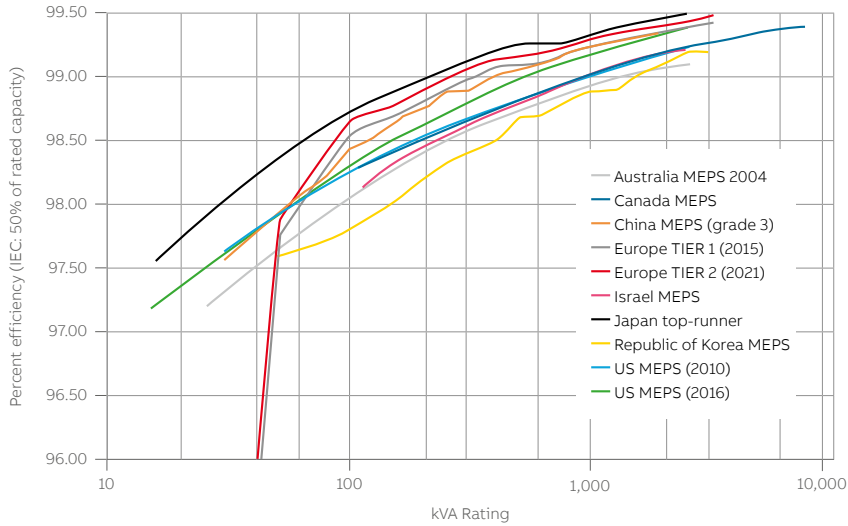

03

Other techniques improve overall cost-effectiveness and performance:

- Transformer intelligence via digitalization – ie, the collection of monitoring and service data to better use the existing assets and increase their availability and life expectancy.
- Transformer life cycle management.
- Reusing or recycling materials at the end of life.

**Battling the losses by design**

Transformer losses have three main components: load losses, no-load losses and auxiliary losses.

**Load losses**

Load losses are created by current circulation along the windings and will vary with the transformer load. Regardless of the type of transformer, 2-D and 3-D software tools, together with ABB expertise, allow the designer to minimize these losses, especially those that cannot be calculated easily – ie, the losses due to leakage flux (also called stray losses). These losses can be reduced with magnetic shunts, which are basically collectors or shields that avoid leakage flux going to areas like the tank walls, where the flux would create even higher losses →4.

**No-load losses**

No-load losses are the losses created in the transformer magnetic circuit due to the magnetic flux circulation through it. These losses are incurred from the very first moment that the transformer is energized and do not depend on the transformer load level. The use of new and more efficient electrical steels reduces these losses. The electrical steel specific losses, defined as losses per unit mass at certain conditions, range roughly from 1.22 to 0.70 W/kg, meaning that depending on the type of material selected, the no-load losses can be reduced by up to 57 percent from one case to another. Furthermore, there are ongoing developments in the field of amorphous electrical steels to further reduce losses. The use of these amorphous materials is, however, currently limited to small transformers.

**Auxiliary losses**

Auxiliary losses are the losses from the transformer control cabinet and accessories – ie, mainly cooling equipment such as fans and pumps. Even for a certain level of load plus no-load losses, there can be significant differences in terms of transformer internal temperatures that will determine the dimensions of the cooling equipment and therefore its energy consumption.

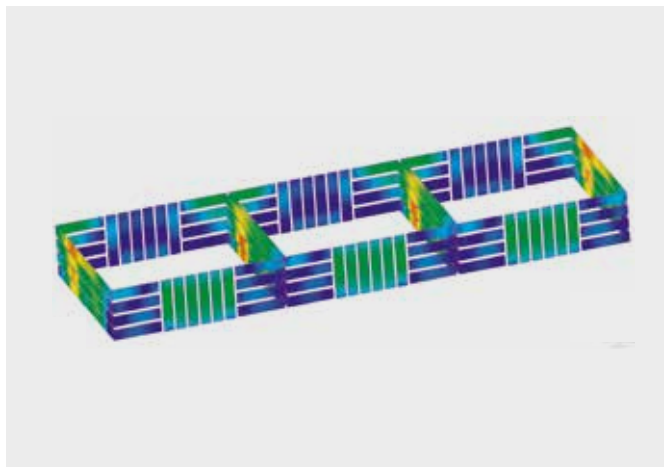

04a

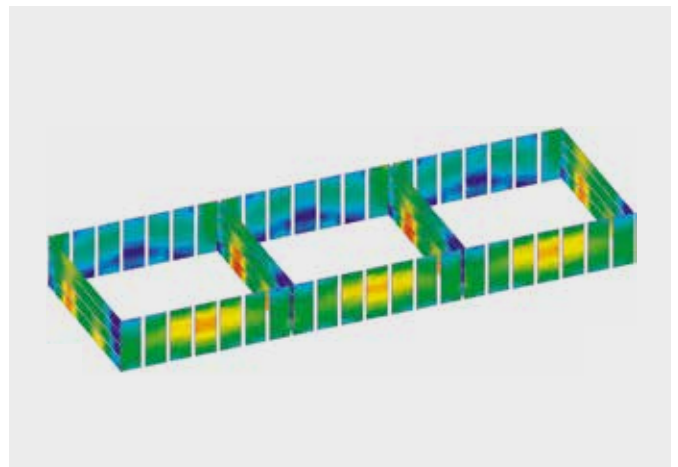

04b

—  
05 ABB's Effilight traction transformer.

—  
06 Examples of efficiency comparison between the classic solution and ABB's Effilight.

06a Comparison of transformer efficiency as a function of the output power. Roof-mounted 1.1 MVA, 15 kV, 16.7 Hz to 25 kV 50 Hz traction transformer. Effilight offers a significant improvement in terms of efficiency compared to the classical technology in the case of bi-system traction transformers too.

06b Typical efficiency vs. weight curve for a roof-mounted 1.1 MVA, 15 kV, 16.7 Hz traction transformer. Increasing efficiency always requires increasing weight. Since Effilight offers a significant reduction of weight at equal efficiency, it is possible to get drastically improved efficiency compared to the classical technology at the same weight.

—  
07 The ABB transformer efficiency portal – an ABB Web site that provides a transformer cost and energy efficiency calculator and information on all aspects of transformer efficiency.

—  
**Reference**  
[1] The Clean Energy Ministerial (CEM) and the International Partnership for Energy Efficiency Cooperation (IPEEC), "SEAD Standards & Labelling Working Group Distribution Transformers Collaboration. Part 1: Comparison of Efficiency Programmes for Distribution Transformers," 2013.

Tools such as computational fluid dynamics (CFD) modelling are used to calculate these temperatures, for liquid-filled or air cooled (dry-type) transformers, and thus allow the correct specification of the cooling equipment.

**Transportation industry case study: Effilight® traction transformer**

One case that exemplifies ABB efforts toward energy efficiency in transformers is the Effilight® traction transformer →5.

Over half the world's trains are powered by ABB traction transformers. Traditionally made of iron and copper, traction transformers are among the heavier components on a train. These transformers use oil for insulation and cooling, as oil has excellent electrical insulating properties and high reliability.

ABB's Effilight traction transformer opens up new opportunities in rail vehicle design by reducing the weight of onboard components and ensuring more energy-efficient rail networks, two of the rail industry's priority objective →6.

The benefits for the user are related to:

- Reliability and proven lifetime
- Optimization of weight, losses and energy consumption (energy costs represent around 10 percent of all rail operator expenses)
- Design flexibility (the possibility to have the same part for different mounting positions)
- Life cycle cost reduction, in terms of investment and maintenance.

The first commercial order for Effilight is for 42 units on 21 trains, the initial step of a long-term relationship intended to deliver and install up to 600 traction units for 300 trains by the end of 2024.

**United for efficiency**

In 2016, in line with its commitment to support transformer energy efficiency, ABB became a founding partner of the so-called United for Efficiency (U4E) group. U4E is a public-private partnership led by the United Nations Environment Program (UN Environment) and other major agencies, including the United Nations Development Program (UNDP). The program



Based on an innovative approach to mechanical integration, this major advancement of a proven technology offers unprecedented energy-efficient and lightweight transformers with a smart combination of lower losses and less use of materials.

Effilight uses a unique and patented cell design that reduces the quantity of oil needed by up to 70 percent, without compromising functionality. The technology enables unprecedented weight reduction (up to 20 percent) and energy savings (up to 50 percent) for train manufacturers and rail operators thanks to a unique approach that keeps the oil exactly where it is needed around the windings.

essentially aims to help countries and economies become energy-efficient through collaboration with international companies. This collaboration includes helping governments develop and implement national and regional strategies to improve their energy efficiency – an important element in the goals of the Paris Climate Agreement, agreed in 2016, to limit the pace of climate change.

The partnership focuses on five product categories, including distribution transformers and electric motors (both with ABB representation), with the aim of accelerating and encouraging the uptake of energy-efficient electrical products.

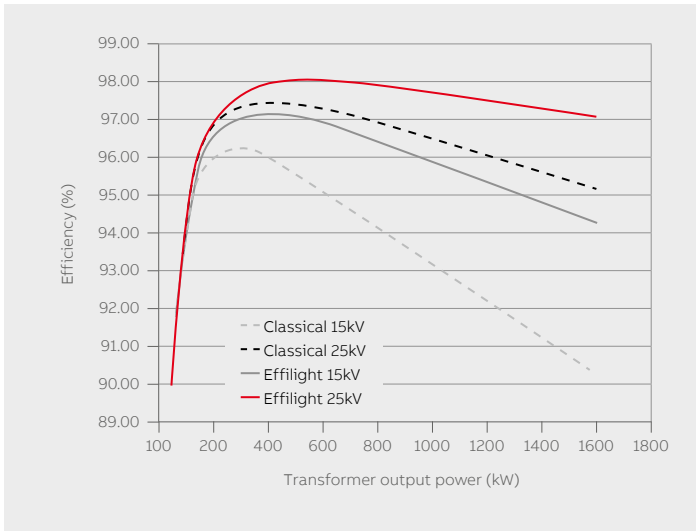

06a

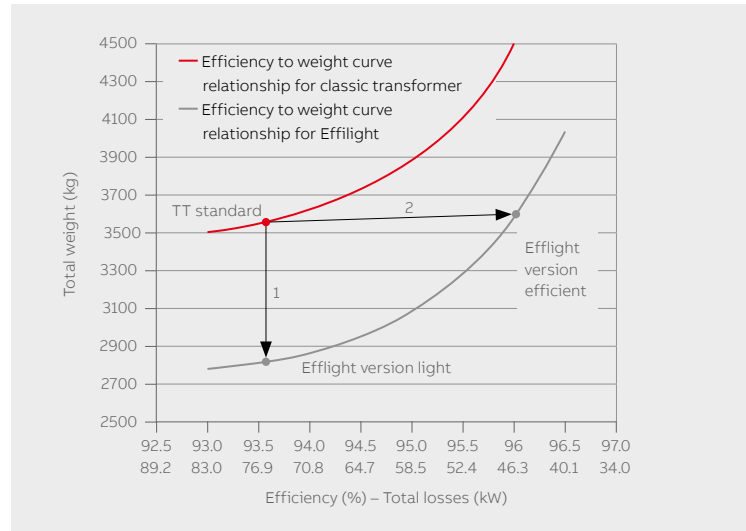

06b

There are two main phases of ABB contribution from the transformers side: the first phase (now concluded) consisted of supporting UN Environment in creating a model that assesses the impact and benefits for relevant countries of moving toward energy-efficient transformers. Here, ABB also provided technical expertise and knowledge about appropriate energy efficiency levels and metrics.

The second phase (global outreach, now starting) will focus on distribution transformers. ABB will develop training packages and tools to support countries and regions in their transition to energy-efficient products and will provide the training. ABB will also foster interregional collaboration to promote energy-efficient products.

ABB is the first transformer manufacturer to join this initiative.

**ABB transformer efficiency portal**

ABB has a dedicated Web page for transformer efficiency that contains a blog and links to relevant articles and Web pages →7. The Web page also includes a useful online tool for calculation of transformer total cost of ownership (TCO). The tool also compares transformers with different initial costs and loss values from the following aspects:

- TCO with payback time on marginal cost.
- Energy consumption.
- CO<sub>2</sub> emission impact (in kg of CO<sub>2</sub>) with the equivalent number of trees needed to compensate the extra emissions caused by the transformer with lower efficiency.

As energy demands rise, ever more attention will be paid to the efficiency of equipment throughout the power network. By innovating on all fronts and by adopting an open, proactive stance to the ongoing evolution of the energy world, ABB will contribute significantly to the evolution of a highly energy-efficient power infrastructure. ●

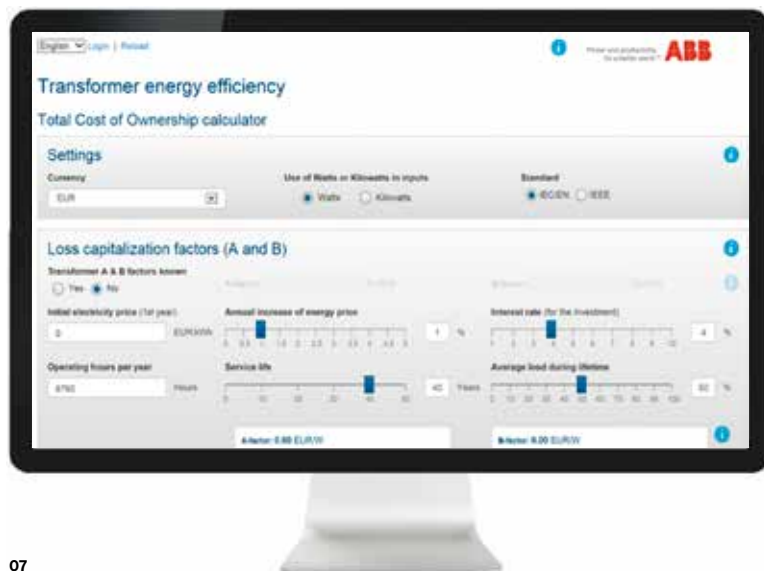

GREENER

# ABB transformers for renewable applications

As wind and solar power penetration reaches new dimensions, ABB's global transformer experience, grid solutions portfolio and digital technologies position it perfectly to supply transformers for renewable electricity grids.



01

**Pawel Prylinski**  
ABB Transformers  
Lodz, Poland

pawel.prylinski@pl.abb.com

**Alberto Rivas**  
ABB Transformers  
Zaragoza, Spain

alberto.rivas@es.abb.com

**Peter Rehnstrom**  
ABB Transformers  
Ludvika, Sweden

Peter.rehnstrom@se.abb.com

**Juan Pedro Gracia**  
ABB Transformers  
Zaragoza, Spain

juan-pedro.gracia@es.abb.com

**Marie-Azeline Faedy**  
ABB Sécheron Ltd.  
Geneva, Switzerland

marie-azeline.faedy@ch.abb.com

**Ilario Scian**  
ABB Transformers  
Monselice, Italy

ilario.scian@it.abb.com

Wind and solar are the fastest-growing sources of electric power today for a few simple reasons: They are renewable energy sources that do not produce greenhouse gases or other emissions; the “fuel” is free and essentially infinite in supply; and as technology matures, equipment costs continue to drop [1] →1-2.

As one of the largest independent suppliers of electrical components, as well as a power technology leader, ABB helps renewable energy customers along the complete value chain to generate, connect, monitor and control power as well as to maintain and optimize their systems.

## Solar applications – the latest transformer technology

ABB transformers provide customized products for solar inverter manufacturers and solar farm developers for both indoor containerized inverter stations and outdoor inverter solutions. As the global technology leader for transformers, ABB offers a deep knowledge of inverter configurations, real operating conditions and specific customer requirements. This knowledge helps ABB customers understand the implications of equipment load cycles and thus optimize their balance of systems. This deeper understanding increases their competitiveness in a market that is extremely dynamic and price-driven.

## Dry-type transformers for solar

ABB dry-type transformers are a dependable asset in any solar project, ensuring the highest product reliability with the broadest service and production footprint in the market. These transformers can help harness the power of the sun in any location and under virtually any conditions - from central inverters at 1,000 V DC for high efficiency in Japan to multi-winding solutions for 1,500 V DC up to 4.6 MVA inside a conventional high cube container for installation and logistics savings. The design adaptability of ABB dry transformers allows owners to integrate the transformer inside the inverter, thus taking the containerized concept to the next level.

Higher-temperature products, like ABB's hi-T Plus concept with upgraded insulation, can allow further cost efficiency in a solar project. Owners can optimize the rated power for multiple ambient temperatures without footprint or weight changes, granting inverter standardization and economy of scale. An upcoming proliferation of utility string inverters will entail a further expansion of compact, safe and virtually maintenance-free dry-type transformers, as MV applications will be integrated into compact substations of up to 5 MW each →3. String solutions from ABB involve a simplification of transformer design requirements and further cost savings while increasing the available power inside conventional, easy-to-ship containers.



ABB has also developed MultiSOLAR, a transformer that can connect up to six inverters in solar plants with a central inverter. This is an efficient and compact solution that can be containerized up to 6 MVA and allows owners to minimize logistic and operational costs.

Energy-efficient designs based on different inverter sizes, and power and voltage ratings, meet all current regulations and standards worldwide. Liquid-filled transformers can be manufactured and tested with mineral oil, synthetic-ester or natural-ester fluids, based on customer requirements.

ABB works closely with equipment owners to optimize designs, not only for the transformer but also for the total cost of ownership of the entire site. This includes ease of installation and full integration. ABB has a global network of factories and expertise, so transformer design and production can take place close to most customers.

The ABB fit-for-purpose approach perfectly matches the modern solar industry’s challenges, such as longer times for funding approvals and shorter times for project execution, and pressure to reduce system and project costs.

**Wind applications -**

**The latest transformer technology**

Wind applications can take advantage of a variety of ABB transformers, both liquid-filled and dry:

**Dry-type transformers for wind**

ABB dry-type transformers provide customized solutions for turbine manufacturers and wind farm developers that can be used in power generation or distribution. As the global technology leader, ABB offers the broadest experience, with a deep knowledge of drivetrain interfaces and real operating conditions that lead to compact and optimized options for up to 8 MVA and E3 certification for such applications. With more than 32 GW worldwide capacity added by transformers delivered since 1998 to more than 55 countries, ABB is truly enabling the power of wind.

01 As costs tumble and climate change awareness increases, growth in solar generation and wind power is far outstripping other forms of energy generation.

02 Indexed electricity generation by fuel (2001-21). The share of renewables in global electricity generation is expected to increase from over 23 percent in 2015 to 28 percent in 2021 as renewable power output is anticipated to grow much faster than global power from coal, natural gas and overall electricity generation [1].

**Liquid-filled transformers for solar**

With market constraints in mind, ABB has developed liquid-filled distribution transformers for the solar industry that pair with various solar inverter sizes. These “fit-for-purpose” transformers are designed to optimize the performance, reliability and return on investment of any solar installation. From residential rooftops to commercial and industrial applications and utility-grade power plants, ABB’s fit-for-purpose solar distribution transformers are specifically matched to different solar inverter sizes and their applications. Streamlined quotation and manufacturing processes shorten lead times so aggressive customer timelines can be met →4.

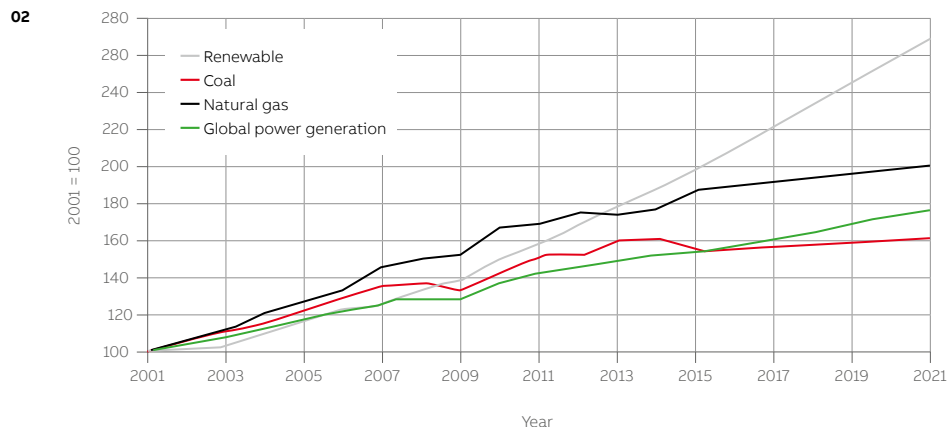



03

Dry transformers are suitable for installation inside the wind turbine, either on the ground floor, at a first level or in the most demanding location, the nacelle →5. In all cases, the design implements a vibration-proof configuration according to IEC 60068-2-6/59 and EN 600. The design also includes a class H insulation system to minimize the footprint and prevent continuous overloads from aging the transformers.

#### Liquid-filled transformers for wind

ABB has a portfolio of liquid-filled distribution transformers for the wind energy sector. These transformers cover all applications from onshore pad-mount or ground-mount to offshore tower- or nacelle-mounted versions.

Within the portfolio, ABB can supply different liquids like mineral oil and ester liquids (both synthetic and natural). Should the requirement be for an onshore padmount, or a very complex offshore in-tower solution, ABB provides a tried and tested cooling design to meet any specific requirements.

With over 5,000 liquid-filled transformers in service in the wind energy industry, ABB has class-leading experience in the field. Designs give appropriate consideration to all the industry-specific characteristics such as harmonics, vibration, voltage spikes, load cycle, short-circuit strengths, etc., giving the purchaser assurance that the design will perform the tasks required while in service.

#### WindSTAR – the world's largest offshore wind turbine transformer

Increasing competitiveness in offshore and onshore wind projects is mainly driven by the increasing power output of the wind turbines. Today, the current maximum power output of an individual unit of around 9 MW is expected to rise to 12-14 MW by the year 2020. To accommodate higher offshore power densities and to reduce the levelized cost of energy (LCoE), wind farm collection grids are moving from 33 kV up to 66 kV.



04

By 2020, 65 percent of the new installations in northern Europe will operate at 66 kV. This boost in voltage level will significantly reduce losses, make generation systems more efficient, deliver life cycle benefits and enable major efficiency gains.

In mid-2017, ABB announced its latest innovation in transformer technology with the introduction of the 66 kV WindSTAR transformer. WindSTAR's modular design can adapt to specific customer requirements and makes installation and commissioning easier than ever before →6-7.

Space is valuable and restricted inside wind turbines and WindSTAR's design is lightweight with a minimal footprint. Forced oil and forced water cooling methods are used to remove heat from the transformer while making the transformer assembly more compact.

The WindSTAR design is as safe, robust and reliable as possible to minimize the costs of repair and maintenance that are generally high in offshore locations. The transformer uses high-temperature insulation paper and an environmentally friendly and high-flashpoint ester. Ester fluids demonstrate a much-reduced risk of fire initiation and propagation, not to mention outstanding self-extinguishing and biodegradability properties.

05



—  
03 Dry-type transformers can be used to remove the risk of fires or spills.

—  
04 Liquid-filled distribution transformers are a proven solution with quicker lead times.

—  
05 Dry-type transformer placed in nacelle for wind application.

—  
06 ABB's WindSTAR – The world's largest offshore wind turbine transformer.

—  
07 WindSTAR characteristics.

**Reference**

[1] International Energy Agency, "Energy Snapshot: Indexed electricity generation by fuel (2001-21)." Available: <https://www.iea.org/newsroom/energysnapshots/indexed-electricity-generation-by-fuel-2001--2021.html>



06

WindSTAR can cope with the rough and exceedingly variable conditions out at sea. The design has been extensively tested against vibration and short circuits, and for further robustness, the transformer's tank has been hermetically sealed by a welded-on cover.

WindSTAR offers a best-in-class solution to withstand sudden variable loading and is available for both 36 and 72.5 kV class applications. Both products are compliant with international standards and regulations for wind turbine transformers. Low overall system losses and improved LCoE ensure a low total cost of ownership.

When it entered service in 2014, the Vestas V164 had the largest installed capacity of any wind turbine. In 2017, the 9 MW version of the V164 set a one-day production record of 216 MWh. It is for power levels such as these that the WindSTAR has been conceived and 128 units of the 33 kV version and 16 units of the 66 kV version have already been delivered to five offshore wind farms in the UK and Germany. Now, more than 70 66 kV units are in the pipeline, with powers ranging from 11 MVA to 14 MVA.

**Building a sustainable future**

ABB also offers transformer solutions for collection stations (offshore platform and onshore) and integration of remote renewable energy sources into the grid with powerful ultrahigh-voltage DC and AC transformers.

ABB's global transformer experience, grid solutions portfolio and digital technologies uniquely position the company to support the complete transformer life cycle. With 40 dedicated transformer service centers, nine service workshops and thousands of team members, ABB helps its customers provide a stronger, smarter and greener grid. ●

High voltage	33 kV	66 kV
KV class	36 kV	72.5 kV
Rated power	> 10 MVA	> 10 MVA
Cooling	KFWF	KFWF
Insulation liquid	Ester	Ester
Insulation material	High-temperature class	High-temperature class
Tapping range	+/- 2 x 2.5%	+/- 2 x 2.5%
Low voltage	> 400 V	> 400 V
Frequency	50 or 60 Hz	50 or 60 Hz



STRONGER

# Shunt reactors improve voltage stability and power quality

ABB's leading position in high and ultrahigh-voltage shunt reactors stems from an uncompromising commitment to quality, innovation and technical excellence. ABB shunt reactors provide innovative technology to meet the needs for voltage stability, power quality and integration of renewable energy.



**Claes T. Bengtsson**  
ABB Transformers  
Ludvika, Sweden

claes.t.bengtsson@  
se.abb.com

The networks for transmitting and distributing electrical energy face new demands due to changes in power generation and load structure. Both commercial and environmental drivers contribute to this demand, as does power quality. Dynamic and time varying effects associated with renewable energy also influence networks. The active power flow in the network and the balance of reactive power must both be regulated to maintain voltage stability – a key to power quality in HV transmission. The voltage level in the grid must also be kept within specified limits regardless of the loading, which varies with time (hourly, daily or seasonally).



**Joel A. Kern**  
ABB Transformers  
Raleigh, NC, United States

joel.a.kern@us.abb.com

**Shunt reactors are cost-effective and reliable**  
Shunt reactors (SR) are commonly used to compensate reactive power and to maintain voltage stability →1. Traditionally, SRs have fixed ratings with no means of voltage regulation. If regulation is needed, fixed reactors are switched in and out along with load variations. However, the resulting large steps in reactance lead to step changes in the system voltage level, especially if the grid is weak. This creates power quality issues and places stress on the breakers.

Wherever power quality is essential, variable shunt reactors (VSR) are an attractive alternative to fixed reactors →2. VSRs have regulation capability and can interact with other regulating devices such as Static Var Compensators (SVC) [1], [2].



—  
01 One of ABB's shunt reactor is shown; it is an absorber of reactive power, thereby increasing the energy efficiency of the system.

VSRs based on transformer tap changers have a regulation speed on the order of minutes between the extreme positions. As load variations occur slowly, i.e. mostly on the order of hours or longer, VSRs based on tap changer technology prove to be the most cost-effective and reliable technology for controllable shunt reactors.

#### **Iron core shunt reactor technology**

ABB's high-voltage shunt reactors are built according to the gapped core concept; this is the dominant core-type reactor on the market today.

For the largest reactors (300 MVar), pulsating forces across air gaps caused by the magnetic field can be as high as 50 tons [3] and appear 100 times per second in 50 Hz systems. Vibrations that result from the electromagnetic forces will generate sound. The degree of vibration depends on the rigidity of the mechanical structure exposed to

the electromagnetic forces. Flexible structures will adjust to the forces more than will a rigid structure. The core column must therefore be very stiff to minimize vibrations [3], [4]. For three-phase reactors, the three wound limbs must also be properly aligned during stacking and accurately levelled at the top yoke. These assembly operations require high precision and skilled workshop operators to achieve low vibration and noise levels.

High-voltage shunt reactors can be built either as single- or three-phase units; the three-phase unit is more economical. Apart from a lower direct investment, the three-phase alternative has lower losses and requires less space in a substation. Reactors are selected for reliability in some regions, where the cost of keeping a spare unit is lower than the cost of a three-phase unit. Shunt reactors at or above 765kV are predominantly single-phase, yet can currently be constructed as three-phase units.

01



High-voltage shunt reactors are designed and optimized according to customers' specifications. Besides the basic design parameters, such as voltage, rated power, linearity etc. limits to losses and sound disturbances also affect design. Generally, the lower the loss, the more material is added to windings and core to keep the current density and flux density low, thereby reducing losses. Similarly, the maximum acceptable sound level of the reactor – often a dimensioning factor in the design process – is important from an environmental and energy saving perspective.

A VSR is based on the same concept as an SR, yet has one or more regulating windings in combination with a tap changer, like a transformer. A VSR is, however, distinctly different from a transformer, because it has a substantially larger regulation range, normally up to between 50 and 60 percent. Larger regulation ranges up to 80 percent at 400 kV can also be achieved, at higher complexity and cost.

Depending on the tap changer position, the magnetic flux will vary within the reactor; the maximum value is achieved at the maximum rating with a minimum number of connected electrical turns. As flux varies, the sound level and losses of the reactor vary depending on tap changer position. If the same number of turns per regulating step are installed, each step, albeit small, will not have exactly the same Mvar rating.

**Field applications of shunt reactors**

Shunt reactors are essential equipment in high-voltage networks operating over long distances and in cable networks to provide voltage stability and increase the transmission efficiency. VSRs are applicable for the compensation of varying load conditions in many circumstances described below.

**Power quality**

Switching in and out of fixed reactors produces steps in the system voltage. This can be avoided by using VSRs, in particular if the grid is weak.

Integration of renewables and wind parks  
Large installations that are connected to the transmission or sub-transmission grid can experience unpredictable fluctuating active-power exchanges and reactive-power fluctuations – serious concern for the operational security of the grid →3. VSRs provide a way to control reactive power fluctuations and allow the wind park operator to comply with the connection requirements of the grid code →2 [5].

**Emerging grids**

VSRs are useful when reactors are installed at HV lines that initially carry a low load that will increase with time – a common scenario in developing economies. One VSR is a more cost-effective solution than two fixed reactors: less expensive, smaller footprint, lower losses and only one breaker.

**Zero crossing**

This phenomenon occurs more often because of the increasing use of HV AC cables at transmission levels. The absence of current zero-crossing can delay the opening of the circuit breaker, thus leaving the system unprotected and vulnerable to failures [6], [7]. One VSR is therefore the most cost-effective solution.

**Tuning of Static Var Compensators (SVC)**

The system operator can adapt the reactive power compensation to the actual load, thus running the grid optimally. If SVCs are installed in the grid, the use of VSRs can provide optimum headroom; the SVC can operate in a minimum loss position.

**Flexible and universal spare**

A VSR can be used in several positions in the grid provided that the voltage levels are similar and can be used as a universal spare if required [1].

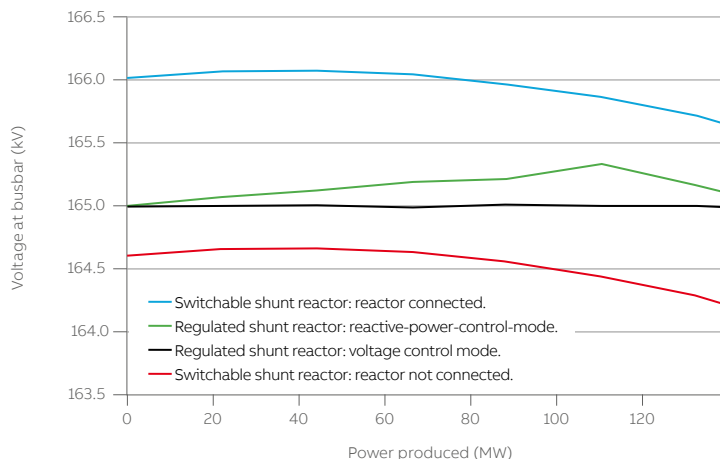

—  
02 Voltage at a 165 kV substation is shown as a function of the active power produced by a wind park; four different cases are illustrated.

—  
03 Different operators have different requirements for the reactive power exchange at the point of connection on large wind farms.



03

#### Air core reactor technology

Air core reactors are available in oil-free and oil-filled solutions. For moderate voltages and power ratings, the most economical type of current limiting reactor is usually a dry-type transformer without an enclosure or active cooling →4. Numerous reactors of this type are in operation around the world, mostly in medium to high-voltage industrial power systems.

Air core reactors have larger footprints than iron-core options. As a result, the magnetic field that spreads freely in the surroundings may cause excessive heating of iron reinforcements in objects like concrete walls. For this reason these objects should be located at sufficient distances so that magnetic field strength values are below 80 A/m at the floor and ceiling and below 30 A/m at adjacent walls.

ABB's outdoor air core reactors utilize a proprietary construction that gives the coils the industry's highest levels of mechanical strength for short circuit and environmental protection. This advanced construction has been validated during decades of robust use by traction rolling stock and in offshore oil and gas production facilities. The construction features a vacuum impregnation process that uses a unique Class H epoxy resin, a dedicated oven-curing cycle to give the reactor additional mechanical strength and a final coating of protective varnish to shield against UV and corrosive elements.

#### Field applications of air core reactors

Air core reactors are used for a variety of industrial and utility field applications: harmonic filters, shunt reactors, short-circuit current limiting, thyristor controlled reactors, inrush damping, neutral grounding, smoothing and electrical arc furnaces.

Harmonic filters are typically installed with capacitors and resistors, close to the source of harmonics to provide a low impedance path for harmonic currents; they are tuned to a specific frequency to cancel or mitigate the relevant harmonic.

Shunt reactors are employed when the compensation of the capacity reactive power is required; where lightly loaded long transmission lines or cables are used. They are also installed on the tertiary winding of a power transformer or on the substation busbar system.

Short-circuit current limiters reduce the short-circuit current to values accepted by the installed circuit breakers when faults occur. Consequently, standard equipment can be installed in the network for high short-circuit currents.

Thyristor controlled reactors (TCR) are employed in SVC systems for dynamic load balance in industrial plants where large variable loads are installed. TCR reactors, unlike shunt reactors, use thyristor valves to continuously regulate current.

Inrush damping is commonly installed in series with a shunt capacitor bank, which functions to limit the inrush currents due to switching and the outrush current of the capacitor bank.

—  
04 Three-phase, stacked outdoor air core reactors.

—  
05 History of shunt reactor development.

References

[1] K. Ryen et al., "Application of Variable Shunt Reactors in High Voltage Networks," Cigré A2/C4 Colloquium Zurich, 2013.

[2] C. Bengtsson et al., "Variable Shunt Reactors: Applications and System Aspects," Cigré, paper A2-211, 2014.

[3] C. Bengtsson et al., "Design and Testing of 300 Mvar Shunt Reactors," Cigré, paper A2-305, 2008.

[4] C. Bengtsson et al., "Field Performance and Sound of Shunt Reactors in Service," Cigré, paper A2-306, 2008.

[5] M. Bollen et al., "Application of Regulated Shunt Reactor for Off-Shore Wind Farms," Cigré Colloquium Bruges, paper 42, 2007.

[6] F. Faria da Silva et al., "Methods to Minimize Zero Miss Phenomenon," IEEE Trans. on Power Delivery, TPWRD-00683-2009.

[7] S. Wijesinghe et al., "Transients Following the Energizing of High Voltage AC Cables with Shunt Compensation," International Conference on Power Systems Transients (IPST2013), Vancouver, July 2013.

Neutral grounding is installed between the network neutral point and earth to limit the line-to-earth fault current. In balanced networks the through current is nil even though the networks are designed with a continuous current in mind; this is due to the unbalance of the network.

Smoothing reduces the harmonic voltage and currents in DC lines and the ripple in the DC currents. This is mainly used where large rectifiers are installed, in traction substations or in HVDC substations.

Electrical Arc Furnaces (EAF) are typically installed in series with the primary power transformer in smelter plants. Particular care to the mechanical



04

1969	The world's first 400 kV shunt reactor
2004	Introduction of Variable Shunt Reactors
2008	Testing of world's largest 3 phase reactor, 300 MVar/400 kV at full power
2009	The world's largest Variable Shunt Reactor, 200 MVar/420 kV
2011	VSRs with 60 % regulation range at 400 kV
2016	VSRs with 80 % regulation range at 400 kV

05

construction is made to manage the high forces in the winding induced by the switching operations. Furthermore, these reactors are often equipped with taps to increase operational efficiency.

**New and future technologies**

Since the introduction of the gapped-core shunt reactor in the late 1960's, ABB has delivered more than 2,950 shunt reactors to around 60 different countries. Today, ABB has the capacity to deliver and test both fixed SRs and variable SRs with extremely high ratings →5.

Customer demands and competition in the energy market have increased over the last decade. Environmental concerns drive growth in renewable energy, extending the use of cable networks and generating an interest in producing lower noise levels. Recognizing these trends, ABB offers shunt reactors tailored to these specific applications eg, ultralow noise reactors without the need for external sound damping; three-phase SRs that operate at 765 kV, and the ability to custom design and build VSRs at 765 kV. Relying on experience and know-how, ABB continues to set new limits for reactors and to provide new sophisticated products to meet the often complex needs of customers. ●

---

STRONGER

# ABB's transformers for special applications meet special needs

Designed to be flexible, compact, and adaptable, ABB's specialized transformers are available in a broad range of voltage levels and power ratings; units for subsea or mobile substations and data centers operate with reduced losses.

**Esa Virtanen**  
ABB GPG OY Transformers  
Vaasa, Finland

esa.virtanen@fi.abb.com

**Joel Kern**  
ABB GPG Dry Transformers  
Raleigh, NC, United States

joel.a.kern@us.abb.com

**Pablo Pacheco**  
GPG Power Transformers  
Córdoba, Spain

pablo.pacheco@  
es.abb.com

**Ruggero Bordon**  
ABB GPG Power  
Transformers  
Monselice, Italy

ruggero.bordon@  
it.abb.com

For complex applications or harsh conditions standard transformer products might not be feasible. Drawing on 100 years of experience and a global footprint, ABB has developed special application transformers with this in mind. High quality materials for core and winding, improved components and perfected connection technologies allow ABB to develop transformers to suit the end user; the result is reduced power losses and extended product lifetime. In this way, ABB meets customers' technological demands while reducing investment time.

## Data centers

Data center technology is dynamic and continually expanding – ABB ensures safe, reliable, and efficient operation of these invaluable information fortresses →1. Building on its background in supplying mission critical power and automation technologies, ABB has developed a transformer that can operate safely with fast-acting breakers to provide reliable commissioning and load-bank switching operations.

01



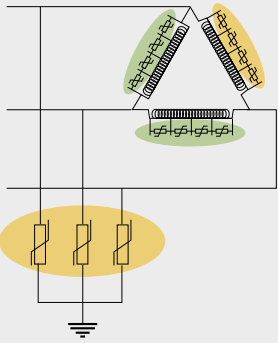

02



Switching of fast-acting breakers, such as vacuum and SF6 breakers, can produce fast transient overvoltages inside transformer windings; some of which lead to failures, with subsequent downtime and irreparable equipment; both of which are incredibly costly to network managers. ABB's Transient Voltage Resistant™ Transformer (TVRT™) provides complete peace of mind during network switching operations →2. The TVRT functions in any electrical network because it is the only solution that controls transient voltages. All its components are oil-free, which greatly reduces installation costs and removes the risk of fires or spills; this is the safest solution for people, property and the environment.

The development of the TVRT by ABB engineers led to the knowledge that switching transients are generated inside of the windings, unlike lightning voltage transients. Furthermore, overvoltages caused by high frequency re-ignitions are the source of the major voltage stress, not amplification of voltage due to resonance inside the transformer, as was previously thought. With that insight, ABB's engineers addressed the problem and provided a simple solution: varistors are placed strategically along the windings in proprietary arrangements to limit transient overvoltages for re-ignitions that may occur inside of the breaker as well as for any amplified voltages from harmonic resonance inside of the transformer. Combined with advanced winding design, this engineered technology controls peak voltages that might occur without the need to know the characteristics of the connected system.

The TVRT technology also eliminates the risk and maintenance associated with oil-filled capacitors. This is particularly important for data centers that rely on dry-type transformers to lower the need for maintenance and reduce the risk of fire.

#### Subsea applications

ABB delivered the world's first commercial subsea transformers in 1998 – a pioneering achievement. Robust, maintenance-free and exceptionally reliable, transformers are routinely used nowadays to power the field equipment of the oil and gas



03

industry that is located on the seabed: boosters, pumps, compressors, pipeline heating systems and frequency converters →3. In the near future, subsea transformers and reactors will be used for grid connections of wave power, tidal turbines and offshore wind parks.

Traditional production facilities, without subsea electric machinery, must cope with the constant decrease of the pressure of the reservoir and a shortened economic lifetime of the field. Typically, subsea booster pumps increase the pressure of oil flow and water pumps raise the oil by injecting water into the reservoir, thereby increasing the lifetime and productivity of the wells. Compressors raise the pressure of the gas and increase the flow from the seabed to shore along the gas pipeline. Subsea high-voltage (HV) transformers allow pumps and compressors to be placed farther away from the existing power generation and supply point.

Electric motors located on production facilities, controlled by topside drive these pumps and compressors. Long HV cables supply power from the topside drives to the subsea machinery situated apart from the topside installation. Step-down subsea transformers are then installed at the seabed nearby to adapt the supplied high voltage to the operation voltage of the machinery. Higher transmission voltage reduces the load current and therefore the size and weight of the cables and the voltage drop in the cable.

Dedicated subsea power distribution grids can be constructed with constant voltage and frequency (50/60/16.7 Hz) with a main subsea transformer and a subsea power distribution grid on its low voltage side. Recently, ABB has successfully conducted underwater tests of a drive unit that includes an integrated subsea transformer; this demonstrates that power transformers up to 100 MVA can be manufactured and operated.

ABB's subsea transformers are designed to operate at great depth and extreme atmospheric pressure. The devices are liquid-filled

—  
01 Data centers count on reliable power, which ABB's TVRT makes possible.

—  
02 TVRT is designed specifically to resist load-bank switching operations.

—  
03 ABB's rugged subsea power transformers deliver the power that makes subsea exploration by the oil and gas industry feasible.

—  
04 Polytransformers rely on a multi-voltage approach and are compact; they can be shipped and installed in any substation.

and pressure-compensated to keep the internal pressure near that of the external water.

ABB uses high-quality insulating oil with a low expansion coefficient and high compatibility with other components in the transformer. Because the transformer is housed in a solid corrosion-proof tank that cannot expand, even when hot, the oil is degassed before installation and the tank is provided with a patented pressure compensating system, thereby ensuring safe operations.

Once installed on the seabed, the scope for repairs is limited. ABB has invested in resources to ensure that its transformers are maintenance-free and all components are of the highest quality. Rigorous testing enables these transformers to enjoy a long, maintenance-free operating life.

#### **ABB's shells HV mobile transformers for planning**

Nowadays, utilities are asked to prepare detailed contingency plans, to efficiently manage partial grid unavailability in case of a power transformer failure. If failure occurs at a critical substation, with approximately 500 MVA rated power, revenue losses can reach up to \$0.3 million per day, before consideration of financial losses caused by damage to reputation. Two main strategies exist to meet these challenges: replace the failed unit with a local spare unit within the same substation (ie, the traditional N+1 spare approach), or use adaptable transformers that are compact, rapidly deployable multi-voltage solutions. The latter approach is dominant today: a single design with outstanding flexibility that leads to lower investment costs.

The use of HV Mobile transformers →4, can significantly reduce reaction time – ie, a compact single phase unit can be transported and put in to

operation in just a few days. It would take weeks or even months to mobilize a large, spare, standard three-phase transformer.

Ten years ago, ABB manufactured the world's first HV mobile transformer using the robust shell technology to give utilities a flexible and fast recovery solution. Thanks to research on materials and winding configurations, this solution has been recently improved: it is more compact, with a higher-rated power and a higher number of voltage ratios; polyvalent transformers can be easily transported to any desired substation rapidly, thereby optimizing grid operation.

Multi-voltage configurations must allow rapid adaptation to different grid voltage levels, to allow full working capabilities. The latest Shell HV mobile units solves these challenges. Successfully tested in its Córdoba, Spain facility in early 2018, ABB could then design and manufacture a 550 MVA three-phase bank composed of modular hybrid single-phase units, with multi-voltage capacity for different voltage ratio configurations by means of 400-220/220-138-66/33-20 kV rated voltages →5. These are the world's first mobile single-phase transformer units operating at 420 kV with full voltage range and capacity OLTC in HV. Now, emergency conditions will not impact the operation of these mobile units.

Conceived to provide emergency support for up to fourteen substations spread over an approximate 1000 km<sup>2</sup> area, end users can now count on an optimized spare fleet instead of turning to the typical N+1 approach. This single adaptable modular design solution therefore results in a significant reduction in investment.



05 Simplified diagram shows the possible HV levels, LV levels and tertiary voltage levels that can be adjusted.

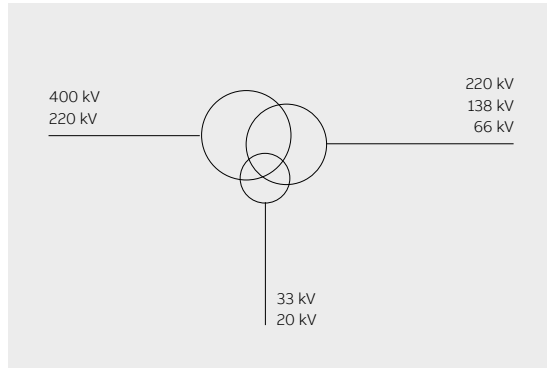

05

06 Power transformers for mobile substations can be easily arranged in many configurations, mounted for air, rail and road transportation and installed almost anywhere.

06a Power transformers at 27MVA 150/8.4kV for MFM "Lean-type", used in the ACEA Substation, Salisano, Italy. The MFM's are skid-mounted and were installed on existing foundations.

06b Generator step-up power transformers at 30/40/60 MVA 11.5/220 kV for MFM, to be coupled with gas turbine-generating units. The MFMs are installed on trailers for road transportation in Algeria.

Additionally, the newest HV mobile unit's limit weight is below 100 tons, and shipping height is less than 3.5 meters to ensure short and easy transit. Nevertheless, the transformer must still operate properly once it reaches the substation. By adapting to the existing system voltage levels at each new location, ABB's mobile solution achieves the greatest voltage ratios available for a HV mobile unit in the industry today. The HV level can be adapted either to 400 kV or 220 kV, LV level can be adjusted to 220 kV, 138 kV or 66 kV, and tertiary voltage can be selected from 33 kV to 20 kV →5. The main voltage can be altered after arrival, and additional minor voltage levels on-load adaptations can be provided by the permanently installed OLTC HV side during operation.

Overall, ABB's shell HV mobile transformers help utilities to deal with emergency contingency plans, thanks to mechanical robustness, compactness and ease of transit, straightforward voltage tap adaptations, and reliability.

**Mobile substations and multi-functional modules**

During contingent events (eg, interim grid connections) utilities still need to provide for power, but how? Enter ABB's Power Transformers for Mobile Substations (MoSS) →6a and Multi-Functional Modules (MFM) →6. These devices enable: power to be supplied during emergency or planned outages, loads to be moved and the integration of distributed or renewable power and generation.

Completely assembled, these units are mobile and ready-to-connect. Designed to comply with any grid codes, these power transformers are invaluable for the demands of special substations.

06a



Available for various voltages and power ratings, the transformers are reliable – supplying high-quality energy to many different substation configurations and applications:

- Dispersed and unpredictable generation sites
- Generation from renewable sources
- Fast-recovery plan due to aging of the existing plant
- Skid mounted arrangement to limit civil works
- Fully relocatable modularized switchyard
- Power supply to facilitate projects by providing an alternative temporary supply in substations
- Emergency installations in adverse environmental conditions

Most recently, ABB moved the first generator step-up (GSU) 60 MVA and 220 kV power transformer on a single trailer in combination with the high-voltage hybrid switchgear PASS module (Plug and Switch System) – forming a fully assembled MFM – to the energy grid in Algeria →6b. In cooperation with Energy Services Inc. (ESI), a Pratt & Whitney affiliated engineering group, this concept has been developed for the power supply through their MOBILEPAC® self-contained gas turbine-powered electric generating units, which feed the GSU power transformers rated at 30/40/60 MVA, 11.5/220 kV, BIL 1050 kV.

This special power transformer is designed with three cooling stages and is integrated to the PASS through oil-SF6 bushings. The MFM's are then equipped with synchronizing relays for the generator gas turbine and digital relays for control, protection and metering. The compact design of these GSU power transformers for MFM and the MOBILEPAC® power supply system allow energy to be supplied less than one day after arrival. Currently, in operation in four different locations in Algeria, these units guarantee flexibility and adaptability to customers, who count on ABB to meet the unique demands in the transformer market.

"ESI chose ABB's MFM solution on account of its compact design, speed of delivery as well as ABB's commitment to supply products as per stringent technical specifications, thereby paving the way for this important collaboration." stated Larry Pitts. ●

06b



STRONGER

# Power fulfillment with ABB's UHVDC and UHVAC transformers

By enabling high transmission voltages, large amounts of electric power can be transmitted over great distances at high efficiency. ABB has made groundbreaking developments in UHVDC and UHVAC transmission; today 1,100 kV DC and 1,200 kV AC is possible.

**Mattias Viksten**  
**Markus Pettersson**  
HVDC transformers  
Ludvika, Sweden

mattias.viksten@  
se.abb.com  
markus.pettersson@  
se.abb.com

**Ryan Ladd**  
Power Transformers  
Ludvika, Sweden  
ryan.ladd@se.abb.com

Energy demands are growing and a 70 percent increase in electricity consumption anticipated by 2040, with over half of that growth expected in India and China [1]. As renewables increasingly become part of power generation in these countries, the need to transmit energy greater distances with reduced losses becomes ever more desirable. However, the renewable energy sources can be located thousands of kilometers away from the load centers where electricity is needed. In these extreme cases, ultrahigh-voltage (UHV) is often the most economical way to transmit the growing amount of power, and converter transformers are the key

technology for the essential link between the AC network and DC systems.

ABB has pioneered this enabling technology, working to increase voltage levels and developing groundbreaking components to meet the stringent requirements to transmit unprecedented power capacity ever farther under the harshest field conditions. ABB's 100 years of experience and expertise in the design and manufacture of transformers, along with a pioneering role in the development of HVDC transformer technology in the 1950s, provides the basis for their scientists and

01

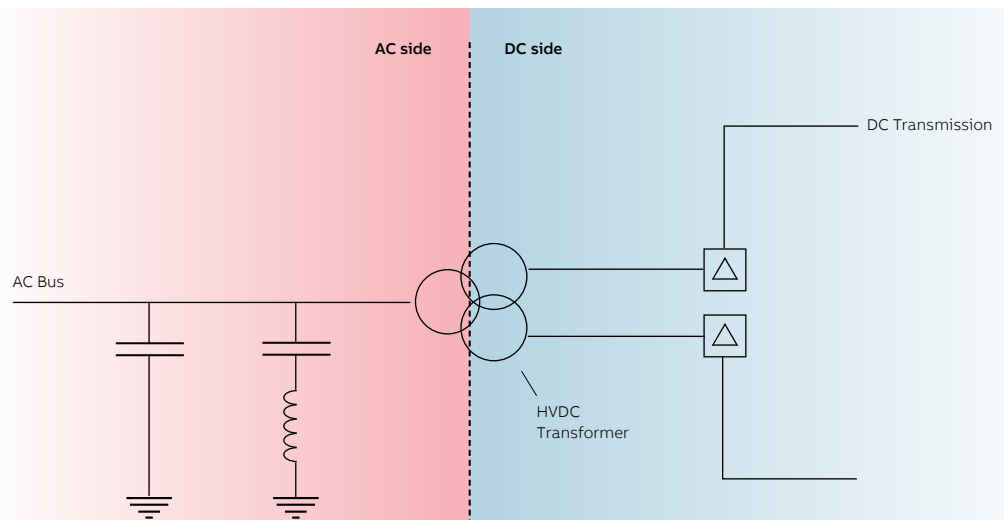



02

engineers to reach milestones in the development of power transmission, thereby establishing world records time and time again.

The high-voltage power transformers developed by ABB for 1,100 kV DC and 1,200 kV AC utilize the most advanced technology available. The most notable advancements have been made in improving dielectric performance but developments have also been achieved in all associated fields, such as thermal and mechanical performance.

#### **The HVDC converter transformer**

The HVDC converter transformer is unique in terms of the challenges it must overcome to function reliably and efficiently. Acting as the electrical and mechanical interface between the AC system and the DC converter, such transformers are exposed to the demands of both systems simultaneously →1.

The main function of the HVDC converter transformer is to insulate the DC-voltage of the converter valve from the AC-network to which the HVDC system is connected. All the power that flows through the HVDC system passes the converter transformers, thereby delivering current at a suitable voltage level to the converter valve, transformed from the AC network voltage level.

Converter transformers are typically large in terms of physical size due in part to the high power ratings, and because both windings necessitate a high degree of insulation; the AC winding is often connected to high-voltage AC grids while the DC winding has heightened insulation requirements. For this reason, dielectric performance is vital to the design of HVDC converter transformers. Converter transformers must not only withstand AC-stress, but also DC-stress generated during tests and service of the DC transmission system. Designing converter transformers to withstand DC-stress has proven to be one of the most complex and formidable challenges undertaken by engineers who design this enabling technology. Thus, HVDC converter transformers are the most rigorously tested transformers in the entire transformer industry.

Comprehensive testing must also be applied to the bushings and tap-changers. ABB's unique position to design and manufacture these devices in-house – relying on unprecedented expertise and experience allows ABB to develop sophisticated designs and deliver the most reliable and optimized transformers possible on schedule.

—  
01 Simplified diagram showing the HVDC converter transformer function at the interface between the AC and DC sides.

—  
02 Power transformer for 800 kV UHVDC transmission is shown.

—  
03 The world's first 1,100 kV DC UHVDC could transmit 12 GW electricity over 3,000 km.

### Development of UHVDC converter transformers

The Itaipu HVDC power link in Brazil, developed and installed by ABB in the early 1980's, was a complex megaproject that pushed the limits of voltage levels and power capacity beyond the then established norms. The system reached an outstanding power transmission level of 3,150 MW and a voltage level of 600 kV DC— a world record voltage level that remained unsurpassed for 25 years. Nearly all devices and components used for this HVDC project were designed and developed by ABB. Viewed in retrospect this project ushered in the modern era of HVDC technology within ABB.

The first Chinese HVDC transmission systems were rated 3,000 MW and 500 kV DC, delivering an Itaipu-type transmission power and voltage level. An important outcome of these early HVDC projects was the realization that it is possible to have single infeed points in networks that can handle substantially more than 3,000 MW. China has access to energy resources, increasingly from renewables, with transmission distances far from load centers – ie, 2,000 km. The possibility of such

a large power infeed and the enormous distances to the load led to the investigation of a new voltage level of 800 kV DC— ultrahigh-voltage DC (UHVDC). Thus, an even higher power transmission rating was feasible; a rating that is required by the Chinese electric energy market. The Xiangjiaba-Shanghai HVDC project was thus the first 800 kV UHVDC transmission system to go into commercial operation with a power rating of 6,400 MW and a transmission voltage of 800 kV DC; it has operated successfully since 2010 [1] →2.

The ability to transmit huge amounts of power over thousands of kilometers led, in 2011, to the next major HVDC transmission development – 1,100 kV UHVDC. In 2016, ABB was awarded a contract to supply the world's first 1,100 kV DC converter transformers, for the 3,000 km, 12,000 MW Changji-Guquan UHVDC link, inaugurating the commercial development of 1,100 kV DC →3.



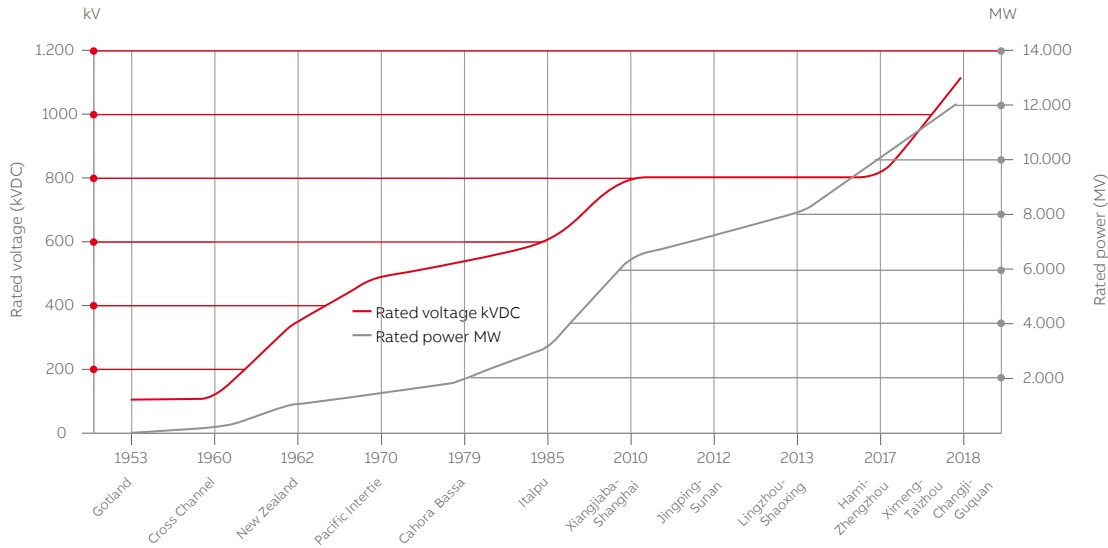

04

The rapid development of HVDC technology over the past five years, from 800 kV DC to 1,100 kV DC, is both noteworthy and remarkable considering that the step from 600 kV DC to 800 kV DC took 25 years →4.

Recently, two further groundbreaking developments have been achieved in the HVDC transformer domain that continue to demonstrate ABB’s leadership role in transformer innovation and customer commitment. One such advancement concerns the power rating for 800 kV DC transmission links, which was increased from 8,000 MW to 10,000 MW. To raise the power rating by 25 percent, ABB redesigned the thermal system to cope with the increased current for the converter transformer. The technical challenge of increased physical size and scale due to the power increase was also successfully addressed. Consequently, ABB supplied converter transformers for the world’s first 10,000 MW, 800 kV UHVDC transmission project and other similar projects.

Another breakthrough concerns the AC-voltage level of HVDC converter transformers. ABB has developed the ability to interconnect all existing DC-transmission voltage levels to all existing AC network voltage levels. The LingShao project was the first commercial application of this new technology. ABB’s converter transformers facilitated the interconnection of 750 kV AC network with an 8,000 MW, 800 kV HVDC-transmission. The successful type testing of this technology resulted in a contract award – the JiuQuan-Hunan project. The supply of leading edge converter transformers and components facilitates long distance transmission of electricity with reduced losses and showcases the ability of HVDC to reinforce the AC grid.

In the first commercial application of 1,100 kV UHVDC-transmission, ABB’s converter transformers are also connected to a 750 kV AC network; this demonstrates the trend of UHVAC to UHVDC interconnection.

**UHVAC transformers**

Lately, ABB has been able to raise the voltage level of AC networks and significantly improve transformer capabilities. The same motivation was used to drive gains in AC voltages to facilitate the efficient long distance transmission of electricity.

Although ABB has been producing UHVAC transformers for many years, a major breakthrough was achieved in 2016 when ABB delivered the world’s first commercial 1,200 kV AC transformer to a substation in India. Fully assembled, this single-phase 333 MVA, 1,200 kV autotransformer weighs 270 tons and is over 9 meters in length, more than 8 meters wide and more than 18 meters in height. ABB’s HV bushing extends 11.5 meters from the top of the transformer tank, which weighs up to 6 tons →5.

**Case study – the 1,100 kV DC project**

Major load centers are located in the eastern region of China, while a significant amount of its energy resources, such as hydropower, are located in the west and northwest [1]. The expansive geography and increased energy demand experienced over the last decade have prompted the buildup of ultrahigh-voltage capacity to transmit larger amounts of power over greater distances with minimum losses. One example of this is the 1,100 kV Changji-Guquan UHVDC project that will transmit 12 GW from the Xinjiang region in the Northwest to Anhui province in eastern China and will set a new world record in terms of distance, voltage level, and transmission capacity – a 50 percent increase in transmission capacity compared to the existing 800 kV 8 GW UHVDC currently in operation [1].

—  
04 The advancement of HVDC converter transformer technology has led to flexibility in HVDC transmissions — almost any conceivable rating combination is possible.

—  
05 ABB's 1,200 kV AC transformer was developed, manufactured and tested at ABB's Vadodra facility in India and currently supports India's central transmission utility, at Bina India.

#### References

[1] Game Changers in the Energy System Emerging Themes Reshaping the Energy Landscape, McKinsey & Company, World Economic Forum 2017, "www3.weforum.org/docs/WEF\_Game\_Changers\_in\_the\_Energy\_System.pdf"  
[2] M. Berglund, M. Peterssen, T. Freyhult, R. Montano, "Developments in UHVDC and UHVAC Transmission Power transformers," ABB white paper, 2016.

The giant converter transformers developed for this project are essential because the transmission distance will be extended from around 2,000 km to over 3,000 km, thereby playing a key role in integrating remote renewables on a large scale. Power can then be transmitted over greater distances; this will facilitate a more interconnected grid. When fully operational, this UHVDC link will deliver enough power to meet the needs of a megacity larger than Shanghai.

The single-phase HVDC transformers developed by ABB have a power rating of 607 MVA and an installed weight of more than 800 tons. The DC-side bushings of this transformer are 40 percent longer, three times heavier and have a 30 percent larger diameter than the 800 kV DC bushing. The technical innovation required to design and build components of this size and scale challenge even the world's most advanced production and testing facilities to the limit.

#### ABB Ability™

The ability to monitor and control the performance of transformers that operate at such high powers and voltages is critical. To ensure that operators are alerted in case of any problems, devices that monitor temperatures and transformer oil status are essential and therefore installed.

In the near future, ABB will extend this monitoring capability with the development of the ABB Ability™ Power Transformer. This package of integrated devices will enable sophisticated aggregation, analysis and management of transformer health data – ensuring customers have access to the most reliable and efficient product possible and providing the means to incorporate all advances in the emerging digital revolution to come [2].

Domain expertise and experience coupled with the most modern test facilities and innovative simulation tools make ABB the world leader in the development of high-voltage power transformers – a market position that allows it to develop the most powerful transformer solutions for its customers. ●



---

 STRONGER

# Transformers to power Indian Railways

Indian Railways has ambitious electrification targets and has found that ABB's comprehensive range of transformers provides an ideal and eco-efficient means not only to power trains, trackside and stations but also to boost rolling stock speed and performance.

**Sanjay Saxena**  
ABB India Ltd.  
Vadodara, India

s.saxena@in.abb.com

**Ilario Scian**  
ABB Spa  
Monselice, Italy

ilario.scian@it.abb.com

**Valter Porcellato**  
ABB Sécheron Ltd.  
Geneva, Switzerland

valter.porcellato@ch.abb.com

**Puneet Arora**  
ABB India Ltd.  
Dry Transformers  
Vadodara, India

puneet.arora@in.abb.com

With approximately 200,000 employees and a rail network that encompasses over 64,000 km of routes, Indian Railways is one of the biggest public-sector enterprises in the world. Of this 64,000 km, around 60 percent is not yet electrified. Indian Railways have a goal to electrify the entire network, at an average rate of around 10 km per day (5,000 km is the 2018-19 target), in order to improve passenger experience and freight handling, reduce carbon emissions from diesel locomotives and save on fuel costs →1-2. The company also looks to employ equipment that reduces overall carbon footprint and improves energy efficiency.

To meet electrification goals, Indian Railways will have to acquire more rolling stock and more of the trackside transformers that supply the 25 kV overhead lines. ABB already supplies locomotive transformers to Indian Railways' original equipment manufacturers (OEMs), like Chittaranjan Locomotive Works (CLW) and Diesel Locomotive works (DLW). In fact, 40 percent of Indian Railways' high-speed trains, like the "Rajdhani" and "Shatabdi" passenger trains, are powered by ABB traction transformers. ABB's 30.24 MVA, trackside transformers, with a low-loss design, are also helping Indian Railways and their engineering, procurement, and construction (EPC) partners in their mission →3-4.



— 01 Indian Railways have an ambitious electrification program both in the national and metro networks. Shown here is a Lucknow Metro train.

The traction transformer market is also driven by measures being taken to combat the rapid urbanization taking place in India, where metro cities and other B-class cities are facing serious traffic jams and vehicle pollution. The Indian Ministry of Housing and Urban Affairs has approved a policy to commission environmentally friendly metro railways in cities having a population of more than one million. This will help to decongest, and reduce pollution levels in, cities and make commuting easier. In support of the Ministry's vision, ABB electric multiple unit (EMU) technology for traction transformers are helping to develop the Metro network in cities like Delhi, Lucknow, Kochi and Mumbai. ABB traction transformers produced in India are suitable for local conditions and are well accepted by Delhi Metro Rail Corporation (DMRC), a central agency for approval of metro equipment.

India's metro networks also have many stations that require distribution auxiliary and rectifier transformers. Here, ABB's latest vacuum-cast-type technology on dry-type distribution transformers is helping metro EPCs to supply auxiliary loads and third-rail systems.

### ABB traction transformers for Indian rolling stock

Traction transformers have two main purposes in trains. Firstly, they convert single-phase, high-voltage (normally ranging from 15 to 25 kV) from the overhead catenary lines to levels (400 V – 1.8 kV) that are usable by the power converters in the train's traction chain. Secondly, traction transformers provide galvanic insulation for safety and protection purposes.

The key specific technical product challenges in India are:

- Harsh environmental conditions: ambient temperature, shock, vibration, flooding, humidity and aridity.
- India Railways' maximum temperature limits (which are 20 °C lower than international standards) for transformer components combined with the high ambient temperatures makes it difficult to cool a contained traction transformer effectively and still maintain a reasonable weight and size.

One of the vital factors for success in India is the ability to manufacture locally – a fact understood by ABB at the end the 1990s when local production of traction transformers for WAP passenger and WAG freight locomotives was started up. ABB has developed its portfolio to cover almost all local rolling stock and propulsion system makers – for example, CLW, DLW, Bombardier, Siemens, Alstom and Medha.

Recently, ABB had its Indian premiere of compact, lightweight transformers that use an ester as cooling fluid. These provide a safer and biodegradable alternative to traditional transformers. The metro in Lucknow was an early recipient of one such (1 MVA, 25 kV/50 Hz) transformer, equipped with one auxiliary and two traction windings. With an inductor included in the tank plus a cooling system, the total transformer weight is just 3,100 kg. This project was the first one awarded by Alstom India to ABB India and all manufacturing is local. The ABB global team delivered to Alstom's satisfaction, which paved the way for the Madhepura Century Project – a very large order – being awarded in 2016 to ABB India by Alstom for 1,600 traction transformers to be delivered over a period of 11 years.

The 5.8 MVA, 25 kV/50 Hz Madhepura transformers have one filter and four traction windings, one three-phase transformer included in the tank and two heat exchangers. The total weight is 7,500 kg. This new transformer allows freight trains to increase their speed from 60 to 90 km/h.

01





02

—  
02 Indian Railways has a route length of over 64,000 km, with running track length of 87,000 km. The total trackage including yards, sidings, etc., exceeds 113,000 km.

—  
03 ABB trackside transformer.

### **ABB liquid-filled trackside transformers support the greener goals of Indian Railways**

Since 2002, ABB has supported Indian train line electrification by providing a variety of single-phase, liquid-filled 21.6/30.24 MVA trackside transformers to connect power systems at 66, 110, 132 and even 220 kV to the 27 kV catenaries that supply power to the electric locomotives. Reliability of the units has been proven by extensive short-circuit tests performed at the Central Power Research Laboratory (CPRI), the accredited testing laboratory with bases in Bangalore and Bhopal.

ABB is currently the largest single supplier of railway trackside transformers to Indian Railways. The transformers are designed to withstand frequent and severe overloads – of up to 200 percent of the nominal load – to support heavy freight and passenger traffic even during the hottest days, when ambient temperatures can exceed 50 °C. The units are equipped with fiber-optic sensors to monitor working conditions and thus optimize their lifetime. Conventional oil filtration units and no-load or on-load tap-changers are used to reduce maintenance intervals and substation personnel levels.

The compact and lightweight design guarantees efficiencies that go well beyond the customer's minimum efficiency requirements to ensure a low total cost of ownership and a greater reduction of carbon footprint during operation. ABB transformers have excellent global references and more than 250 of these units have been manufactured locally – with an excellent history of on-time delivery and short lead time – and installed in the Indian Railways power network.

### **Dry-type transformers for mass rapid transit systems in India**

The self-extinguishing nature of dry-type transformers makes them the ideal choice for installations in busy metro stations →5. These transformers are mostly installed indoors, for example in underground or aboveground metro stations. Because of the tight dimensions in these locations, most of the transformers are supplied with fully removable enclosures that allow for them to be reassembled at the installation site. These enclosures are modular, so their assembly is simple. The light weight and easy handling of aluminum-wound, dry-type transformers has encouraged most metros networks to migrate to them from copper-wound, dry-type transformers. Dry-type transformers in metro stations are used primarily in 24 kV AC systems, third-rail DC systems and monorails.

### **Auxiliary dry-type transformers in the Metro**

Auxiliary dry-type transformers, usually three-phase, are widely used to power heating, ventilation and air-conditioning systems at metro stations – as well as the lighting loads of various associated shops and malls. Normally, transformers with ratings from 1,600 kVA to 3,150 kVA are used in underground metro stations, while lower ratings are used aboveground. ABB has supplied auxiliary dry-type transformers to various metros in India, eg, Delhi Metro Rail Corporation, Ghaziabad Metro, Noida – Greater Noida Metro, Lucknow Metro, Navi-Mumbai Metro, Chennai Metro and, most recently, Ahmedabad Metro.

Predominantly, oil-immersed transformers are used for supplying overhead railway lines of 24 kV AC systems. Recently, ABB successfully commissioned a dry-type, single-phase transformer having a voltage ratio of 33/24 kV (Noida – Greater Noida metro) for this task.

ABB has supplied 12-pulse rectifier, dry-type transformers along with two six-pulse rectifiers for a third-rail DC system. Third-rail DC systems are used as they provide a smoother operation than 24 kV AC systems, though the latter system has a lower initial investment. Reference locations for this application are Kochi Metro Rail Corporation, Kolkata Metro Rail Corporation and, outside of



03



04

—  
04 An array of four ABB trackside transformers installed by Indian Railways.

—  
05 Dry-type transformers are ideal for underground or enclosed applications.

India, Bangkok Metro. ABB has also supplied 12-pulse rectifier, dry-type transformers along with two six-pulse rectifiers for a monorail system. These transformers were additionally equipped with a surge arrester protection system to help the transformer withstand fast transients generated by vacuum circuit breakers during the switching operations. This solution is known as ABB's Transient Voltage Resistant™ Transformer (TVRT) and is specifically designed to withstand voltage transients generated from switching. The reference location for this application is Mumbai Monorail.



05

### On the fast track

ABB, as a technology leader in infrastructure and transportation and with its portfolio of transformers for locomotives and trackside, is helping Indian Railways in their mission to electrify their network. ABB technologies are also helping Indian Railways to provide more powerful freight locomotives, increasing their average speed to 90 km/hr. This increased performance is enabling Indian Railways to haul more freight, increase revenue, shift freight from road to rail, decongest roads and reduce air pollution. And with the introduction of more eco-efficient, ester-filled transformers, fire safety is promoted and environmental impact reduced. ●

### Imprint

#### Editorial Council

**Gerhard Salge**  
Head of Technology,  
Power Grids Division

**Harmeet Bawa**  
Head of Communications,  
Power Grids Division

**Stephane Schaal**  
Technology Manager,  
Business Unit  
Transformers

**Giuseppe Petrelli**  
Marketing & Sales  
Manager, Business Unit  
Transformers

**Namita Asnani**  
Communications  
Manager, Business Unit  
Transformers

#### Publisher

ABB Review is published  
by ABB Group R&D and  
Technology.

ABB Switzerland Ltd.  
ABB Review  
Segelhofstrasse 1K  
CH-5405 Baden-Daettwil  
Switzerland  
abb.review@ch.abb.com

ABB Review is published  
four times a year.  
ABB Review is free of  
charge to those with  
an interest in ABB's  
technology and  
objectives.

For a subscription, please  
contact your nearest  
ABB representative or  
subscribe online at  
[www.abb.com/abbreview](http://www.abb.com/abbreview)

Partial reprints or  
reproductions are  
permitted subject to  
full acknowledgement.  
Complete reprints require  
the publisher's written  
consent.

Publisher and copyright  
©2018  
ABB Switzerland Ltd.  
Baden/Switzerland

Vorarlberger  
Verlagsanstalt GmbH  
6850 Dornbirn/Austria

—  
**Layout**  
DAVILLA AG  
Zurich/Switzerland

—  
**Artwork**  
Konica Minolta  
Marketing Services  
WC1V 7PB London,  
United Kingdom

The information  
contained herein  
reflects the views of  
the authors and is for  
informational purposes  
only. Readers should not  
act upon the information  
contained herein without  
seeking professional  
advice. We make  
publications available  
with the understanding  
that the authors are not  
rendering technical or  
other professional advice  
or opinions on specific  
facts or matters and  
assume no liability  
whatsoever in  
connection with  
their use.

The companies of the ABB  
Group do not make any  
warranty or guarantee,  
or promise, expressed or  
implied, concerning the  
content or accuracy of the  
views expressed herein.

ISSN: 1013-3119

<http://www.abb.com/abbreview>



#### Printer

#### Disclaimer



#### Tablet edition

ABB Review is  
also available  
for your tablet.

Please visit  
[abb.com/abbreview](http://abb.com/abbreview)

#### Stay informed...

Have you ever missed a copy of ABB Review?  
Sign up for the email alert at  
[abb.com/abbreview](http://abb.com/abbreview)  
and never miss another edition.

Please note that when you register for this alert, you will  
receive an email with a confirmation link. Please ensure that  
you have confirmed your registration.





---

# Control your future, transform theirs

## Digitally integrated transformers

Digital natives like Kenny are growing up fast. So is the utilities sector. With changing energy sources and usage, reliable power is more important than ever – and this is exactly what the new ABB Ability™ power and distribution transformers deliver. Digitally enabled right out of the box, optimising asset performance is simple. Early warning prevents failures and the modular, scalable design provides a future-proof solution. So take control of your future, and transform it for the next generation.

[new.abb.com/products/transformers/smart-transformers](https://new.abb.com/products/transformers/smart-transformers)

