

Voltage Neutral Displacement Relay



Customer Benefits

- Ideal for Neutral voltage displacement – detection of E/F irrespective of earthing system.
- Tuned to fundamental frequency
- Operation annunciation in the form of flag
- Environmental friendly
Electing phoratic painting process
- Draw out type case
- Complete dust proof by IP5X class protection

Type VDG 14 Voltage Neutral Displacement Relay

Features

- Insensitive to voltages at third harmonic frequencies
- Identical time/voltage characteristics on all taps
- Simple construction, easily accessible
- Comprehensive range of auxiliary unit ratings

Application

Earth fault protection of generators earthed through a neutral earthing transformer and where immunity to operation on third harmonic frequency is essential capacitor bank protection etc.

General Description

A heavily damped induction disc relay with an adjustable inverse time/voltage characteristic. The coil circuit of the relay is tuned to the supply frequency by a series connected choke and capacitor. These components are energized from a tapped auto-transformer which provides adjustment of the relay voltage setting. At voltages above the setting, the choke saturates and detunes the circuit giving the relay a high continuous voltage rating. Damping of the disc movement is by a removable high retentivity permanent magnet.

The unique method of winding the operating coil ensures that the time/voltage characteristics are identical on each of the voltage taps. Selection of the required voltage setting is by means of a plug setting bridge which has a single insulated plug. Tuned wound shading coils are fitted so that the relay develops maximum torque at the supply frequency and is much less sensitive to voltage at third harmonic frequencies.

The relay operating time can be adjusted by movement of the disc backstop which is controlled by rotating a knurled moulded disc at the base of the graduated time multiplier scale

Type VDG 14 relay is a single pole relay and is available in the single pole version only.

Technical data

Ratings

110V, ac, 50Hz

Settings

5.4, 7.5, 12.5 and 20V, ac, 50Hz

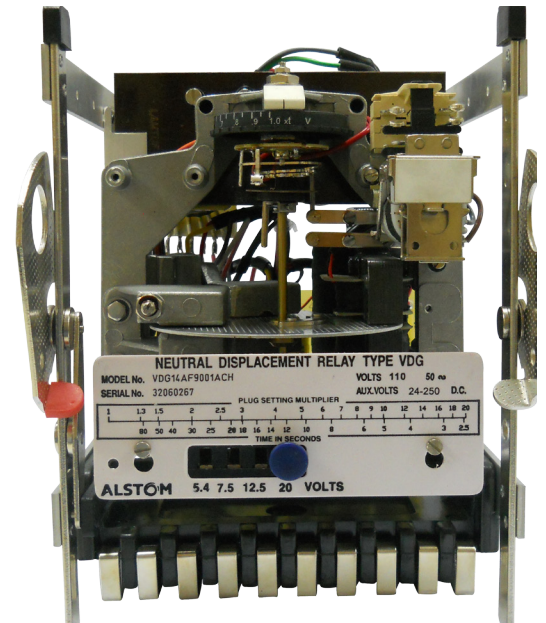

VDG 14 Withdrawn from the case

Third harmonic rejection

The relay will not operate at third harmonic voltages up to 20 times the setting voltage at 50Hz

Resetting voltage

Resets completely at 80% or more of voltage setting.

Time Settings

- Operating time
1.0-1.5 sec at 5 times voltage setting. Time/voltage characteristics are given in Fig 1.
- Resetting time
100 seconds at TMS = 1.0

Burden

Relay setting	Lowest setting (5.4 volts)	Highest setting (20 volts)
VA burden setting	0.22	0.27
VA burden at 110 volts ac	17.00	2.30

Thermal rating

- **Continuous**
120 volts on any setting for 60°C rise in coil temperature
- **Short time**
200 volts on any setting for the duration of the operating time

Accuracy

Error class index – E 5.0 as per BS 142 – 1966
5.0 as per IS 3231-1965

- Timing Error
Operating time at TMS=1.0 Conforms to time/voltage characteristic given in Fig 1, subject to a tolerance of +7.5% at 5 times voltage setting

Auxiliary units and operation indicators

Auxiliary unit with two pairs of self reset contacts arranged to reinforce the disc contact and a hand reset operation indicator provided.

Shunt connected, voltage operated, aux.unit is fitted as standard

Voltage coil ratings

- 30,110 or 220V dc with a nominal burden of 3 watts
- Other coil ratings available on request

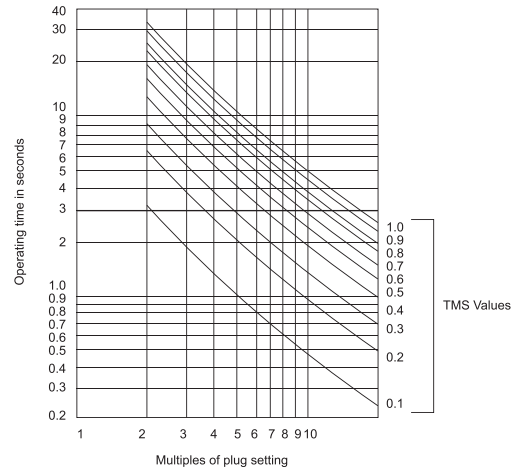

Figure 1 : Time / Voltage characteristics

Contacts

Type of contact	Make and carry for 0.5 second
Disc Contact	2500VA with maxima of 10A and 660V, ac / dc
Auxiliary unit contact	7500VA with maxima of 30A and 660V, ac/ dc

Insulation

The relay meets the requirements of IS 3231-1965/IEC 255-5 series C-2 kv for 1 minute

External and internal circuit connections

See Figure 2

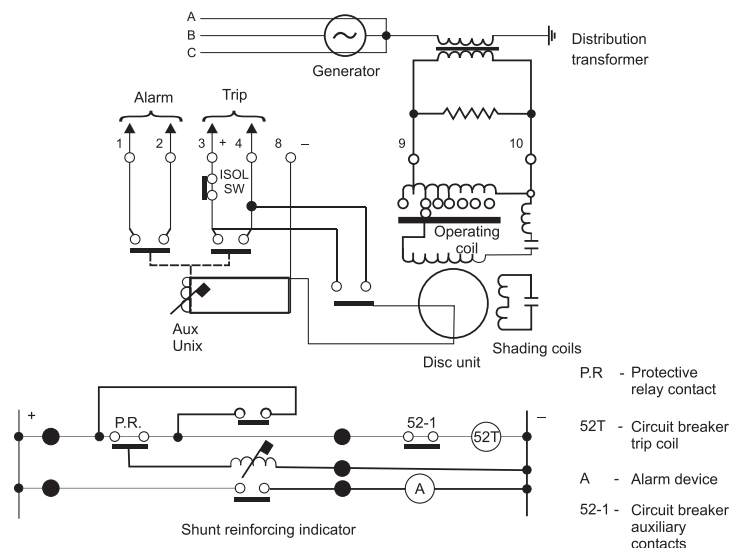

Figure 2: Typical external and internal connections for type VDG 14, generator stator earth fault relay

Dimensions and weights

Relay	Case size	Maximum overall dimensions			Approximate Gross Weight Kg.
		Height mm	Width mm	Depth* mm	
VDG 14	1D vert.	233	170	203	6.5

* Add 76 mm for maximum length of terminal studs, alternatively, 29mm for terminal screws.

The appropriate gross weight given above is inclusive of cartons, mounting appendages and terminal details.

The relays comply fully with the requirements of IS 3231 – 1965 and are suitable for use in normal tropical environments.

Case

1D vertical case suitable for flush mounting and finished egg shell black and tropicalised. Suitable trip insolation switch provided on the cradle assembly

Information required with order

1. System frequency and application
2. Auxiliary voltage

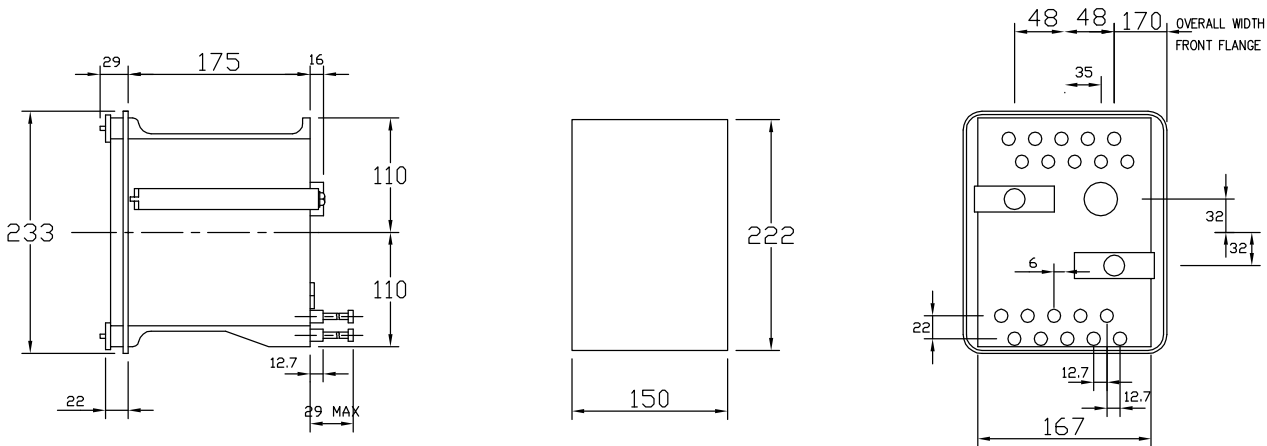

Figure 3 : Case and panel cut-out dimensions for case 1D (all dimensions in mm)

ALSTOM T&D INDIA LIMITED

Pallavaram Works
 19/1, G.S.T. Road,
 Pallavaram, Chennai - 600 043
 Tel: 91-44-2264 8000
 Fax: 91-44-2264 0040

ALSTOM T&D Worldwide Contact Centre:

<http://www.alstom.com/contactcentre/>
 Tel.: +44 (0) 1785 250 070

www.grid.alstom.com

"Alstom logo and any alternative version thereof are trademarks and service marks of Alstom. The other names mentioned, registered or not, are the property of their respective companies. The technical and other data contained in the document are provided for information only. Neither ALSTOM, its officers nor employees accept responsibility for or should be taken as making any representation or warranty (whether express or implied) as to the accuracy or completeness of such data or the achievements of any projected performance criteria where these are indicated. No liability is accepted for any reliance placed upon the information contained in this brochure. Alstom reserves the right to revise or change these data at any time without further notice."