

# VAGM 22

Instantaneous Voltage Relays



### Customer Benefits

- Ideal for over voltage / under voltage application.
- Adjustable voltage rating
- Operation annunciation in the form of flag
- Draw out type case
- Completely dust proof by IP5X class protection

## Instantaneous Voltage Relays

### Type VAGM 22

#### Features

- Adjustable setting range
- Very high drop off / pick up ratio
- Unaffected by normal variation in frequency of input voltage
- Simple and robust construction
- Positive action without chatter

#### Application

Instantaneous over – voltage protection of generators, capacitors etc., definite time undervoltage protection of ac motors, automatic voltage changeover schemes and other instantaneous and definite time under voltage and overvoltage applications requiring adjustable settings.

#### General description

VAGM 22 is standard attracted armature relay with seven equal setting adjustable on a plug board.

A dc coil is used with an internally mounted bridge rectifier to obtain a drop off/pick up ratio of the order of 90%. A resistance connected in series with the coil is tapped suitably and the taps are connected to the plug board to obtain seven equal setting. A capacitor is used to serve as a filter unit for the bridge rectifier and it also acts as a surge suppressor for protection the diodes of the bridge rectifier against high voltage transients.

The dc coil is fitted with a normally open light duty contact which is arranged to energise an auxiliary unit which provides the necessary output contacts.

Type VAGM 22 is a single pole relay with its auxiliary unit.

#### Technical data

##### Voltage rating and setting

Relays are supplied suitable for operation on 110 volts, 50 Hz system and have the following standard setting ranges :

Over voltage relay

110-140% adjustable in seven equal steps

Under-voltage relay

40-80% adjustable in seven equal steps

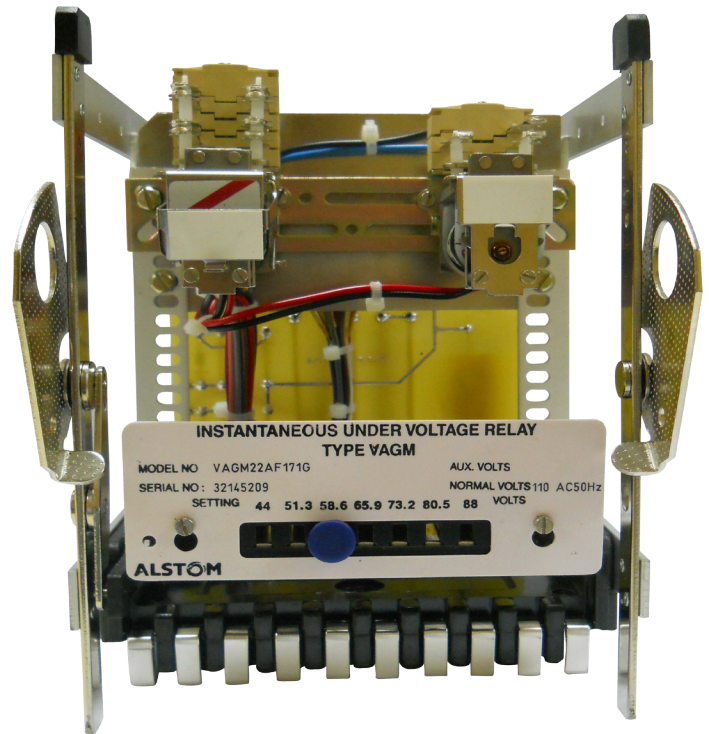

VAGM 22 relay withdrawn from case

#### Resetting voltages

Over voltage relay : 90% of setting voltage

Under – voltage relay : 110% of setting voltage

#### Operating times

Over-voltage relay:

0.060 second at 110% voltage setting

Under voltage relay :

0.025 second at zero voltage. These times are inclusive of the operating time of the associated auxiliary unit.

### Burdens (VAG coil)

Over-voltage relay :

Maximum burden at nominal voltage is 0.9VA

Under-voltage relay :

Maximum burden at nominal voltage (i.e. relay set at the lowest setting) is 2.5 VA.

### Thermal rating

Over – Voltage relay :

The VAG unit can withstand three times the setting voltage on any setting continuously.

Under-voltage relay :

The VAG unit can withstand two times the pick-up (resetting) voltage on any setting continuously.

### Accuracy

The over-voltage and under relays conform to error class index E 5.0 as per BS 142 – 1966 and 5.0 as per IS 3231-1955.

### Operation indicator

The relays can be fitted, if required, with an operation indicator on the auxiliary unit. The indicator is hand reset by means of a push-rod protruding through the relay case. On the under-voltage relay, of reverse operation indicator is fitted i. e. it operates on drop-off or loss of voltage.

### Contacts

Upto three pairs of standard self-reset contacts can be provided on the auxiliary unit of the relay in any combination of ‘Make’ and ‘Break’. The auxiliary unit is always energized by a normally open, light duty contact of the VAG unit in case of under-voltage relay. The auxiliary unit can be fitted with blow-out magnet contacts also, if required, for breaking heavy or highly inductive dc loads.

The normal position, regarding the contacts, is the de-energised position.

### Contact rating : The contacts of the auxiliary unit of the relay are rated as follows :-

Type of contacts	Current	Make & carry continuously	Make & carry for 3.0 sec	Break
Standard	AC	1250 VA with maxima of 5A and 660 V	7500 VA with maxima of 30A and 660V	1250VA with maxima of 5A and 660V
Standard	DC	1250 W with maxima of 5A and 660 V	7500 W with maxima of 30A and 660V	100W (Resistive) or 50 W (inductive) with maxima of 5A and 660V
Heavy duty magnetic blow-out	DC	1250 W with maxima of 5A and 660 V	7500 W with maxima of 30A and 660V	3 ½ KW maximum

### Dimensions and weights

Relay	Case size	Minimum overall dimensions			Approximate gross weight Kg.
		Hight mm	Width mm	Depth* mm	
VAGM 22	1 D Vert.	233	170	203	5.5

\* Add 76 mm for maximum length of terminal studs, alternatively, 29 mm for terminal screws. The approximate gross weight given above is inclusive of cartons, mounting appendages and terminal details. Certified dimensional drawing of case outlines, panel cut-outs and mounting details are available on request. The relays comply fully with the requirements of IS 3231 – 1965 and are suitable for use in normal tropical environments.

### Insulation

The relay meets the requirements of IS 3231 1965/ICE-255-5 Series C-2 kV for 1 minute.

### Case and finish

Relays are supplied in single pole, metal drawout cases suitable for flush mounting are finished eggshell black and tropicalised. The drawout feature considerably simplifies maintenance and permits testing to be carried out easily and quickly. A cradle mounted isolating switch is provided which automatically isolates the trip circuit when the cradle assembly is withdrawn from the case for maintenance. This prevents any inadvertent tripping of the circuit breaker. The case can also be fitted with switches to maintain the under – voltage trip circuits on withdrawal of the relay unit from the case. A filter breather is fitted to equalize pressure inside and outside the case without admitting dust.

### Information required with order

1. Type of relay (under voltage or overvoltage)
2. Nominal Voltage rating. (If other than 110 volts ac suitable interposing VTs will have to be used.)
3. Number and type (Standard or blow out magnet) of 'Make' and 'Break' contacts required.
4. Whether operation indicator required. If so whether any flag inscription is required.
5. Voltage rating of the auxiliary unit(\*)
6. Type of mounting – flush or projection.

(\*) It is preferable to have a dc or separate ac auxiliary voltage supply for the auxiliary unit.

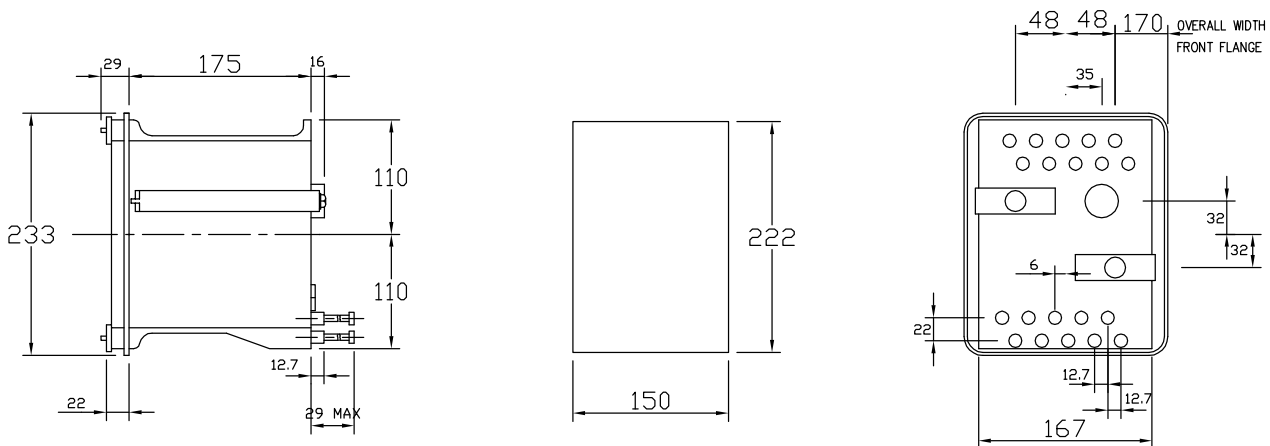

Figure 1 : Case and panel cut-out dimensions for case 1D (all dimensions in mm)

#### ALSTOM T&D INDIA LIMITED

Pallavaram Works  
 19/1, G.S.T. Road,  
 Pallavaram, Chennai - 600 043  
 Tel: 91-44-2264 8000  
 Fax: 91-44-2264 0040

#### ALSTOM T&D Worldwide Contact Centre:

<http://www.alstom.com/contactcentre/>  
 Tel.: +44 (0) 1785 250 070

[www.grid.alstom.com](http://www.grid.alstom.com)