

ODS

Rotary switch



General construction

Switch ODS is of rotary type, compact and on the packet principle. Each individual pack contains two electrically independent double break contacts and a mechanical operating cam driven off a common shaft. Upto 18 packs can be accommodated on a single switch giving a maximum of 36 electrical ways.

Specifications

The ODS Rotary switch meets the requirements of IEC 337-1 control switches - utilisation categories AC11 & DC11 for continuous current ratings upto 20A for voltages upto 660 V AC and DC. Mechanical Endurance class 3 million switching cycles. This switch also meets the requirements of the draft BS for control switches for the same categories, currents, voltages and mechanical endurance class as for the IEC specification.

Mechanical endurance

The switch is capable of completing over 1,500,000 mechanical cycles of operating without the need for maintenance. One cycle of operation being one complete rotation of the switch.

Switch ODS is of rotary type, compact and on the packet principle. Each individual pack contains two electrically independent double break contacts and a mechanical operating cam driven off a common shaft. Upto 18 packs can be accommodated on a single switch giving a maximum of 36 electrical ways.

Components

Switch pack

The individual switch packs which form the basis of the switch are moulded in a self-extinguishing plastic compound with inherent arc quenching and high insulating properties. The contacts and associated moving parts are completely enclosed in the mouldings giving a high degree of dust protection.

Back plate

The back plate of the switch is moulded in the same material as the switch packs.

Mechanism housing

The mechanism housing is moulded in fire resistant material and contains the mechanical parts necessary to provide the stay put, spring return or lost motion device (LMD) for addition of bell alarm contacts on LMD.

Contact system & identification

Each electrical way (of which there are two per pack) comprises two fixed contacts and one moving bridge contact giving a double break per electrical way.

Contacts have domed silver cadmium oxide buttons on the fixed parts and flat silver cadmium oxide buttons on the moving part.

On the outside of each switch pack the identifications +1, 2, +3 and 4 are moulded onto the pack material adjacent to the respective terminals.

Contact bridge system

The contact bridge system comprises a moving contact housed in a slot with a cam follower moulded in nylon material. This cam follower also accommodates a brass roller with a pivoted arrangement. On operation of the switch the brass roller follows the contours of the operation cam causing the contacts to open and close as required.

Customer Benefits

- Rotary type
- Compact design

Cam

The operating cams are injection moulded in nylon. In addition to the large range of popular standard cams which are moulded to their final form or an extensive range of less commonly required cams are available with the profile machined from moulded blanks.

Contact springs

Contact pressure is obtained by two contact springs per way located one on each end of the moving bridge contact.

Common parts

All the operating cams are driven by a common square section steel shaft which is anchored axially within the switch by means of a circlip. A front coupling plate houses a front bearing and a rear bearing is fitted in to the back plate of the switch, both bearings are injection moulded in nylon. The shaft has a datum mark on one face near each end which is used during assembly. The datum mark generally is represented on top of the operating shaft when the switch handle is kept at 12-0' clock position.

Switch types

Control and selector switches

(a) Stayput switch :

The stayput switch is supplied with a 90° or 45° operating angle (upto 4 or upto 8 operating positions) and upto 36 electrical ways can be accommodated in one switch.

(b) Spring return switch :

The spring return switch is designed for 60° operating angle in either direction from the neutral position.

If more than 12 electrical ways are required

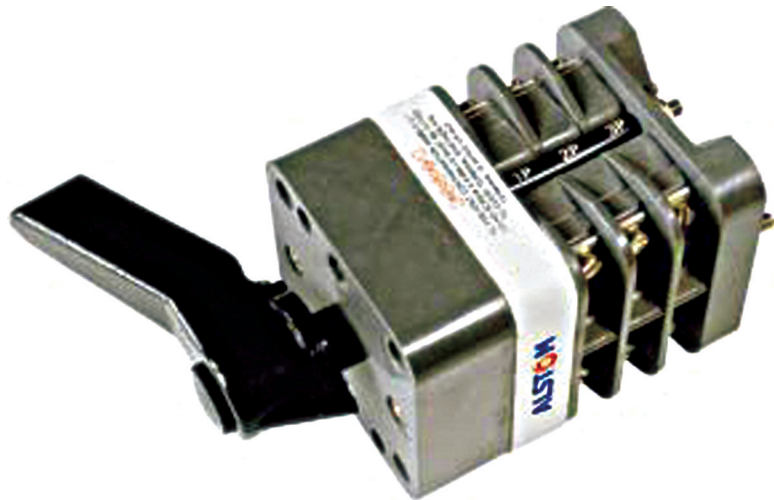

ODS - Stayput type switch

operating 6 ways in either direction then two spring return mechanisms are fitted and the length of the switch is increased by 25.4 mm.

(c) Spring return and lost motion switch :

This type of switch is divided into two parts. The front portion of the switch containing contacts requiring spring return action and the rear portion accommodating contacts for which the lost motion facility is required.

Sequence device

A sequence device can be included in a 3 position spring return switch to prevent two consecutive movements in the clockwise direction from the neutral position.

The addition of a sequence device increases the length of the spring return switch by 25.4 mm.

Handle

Pistol grip - medium type for nonlock and lock types (PM)

Locking facility

Barrel locking

A barrel lock of Yale pattern can be incorporated in the centre of the operating handle lockable in any of the switch positions. It can be supplied with either the "key free switch free" or "key trapped switch free" facility. When .key trapped switch free. facility is offered, the key would be free only after the switch is locked in desired position/ positions. Castel locks (P&S) types can also be provided.

Dimensions of basic switch

Width of switch 66.5
 Height of switch 66.5
 Depth of each pack 12.7 mm
 The overall length of a non-locking selector switch with the maximum 18 packs (36 electrical ways) is 285 mm not taking into account the projection of the shaft and handle in front of the panel.

The equivalent figures for a more usual switch with say 6 packs (12 electrical ways) is only 131.8 mm.

Breaking capacity amp. Dc

Voltage	No. of contacts	Resistive	10msec. TC	Inductive 20msec TC	40msec TC
50	1	20	20	15	6
	2	-	-	20	14
	3	-	-	-	20
125	1	3	1.5	1.5	1
	2	20	10	10	5
	3	-	20	20	10
250	1	1	0.5	0.3	0.2
	2	5	2	1	0.5
	3	20	10	4	1



Switch with barrel lock

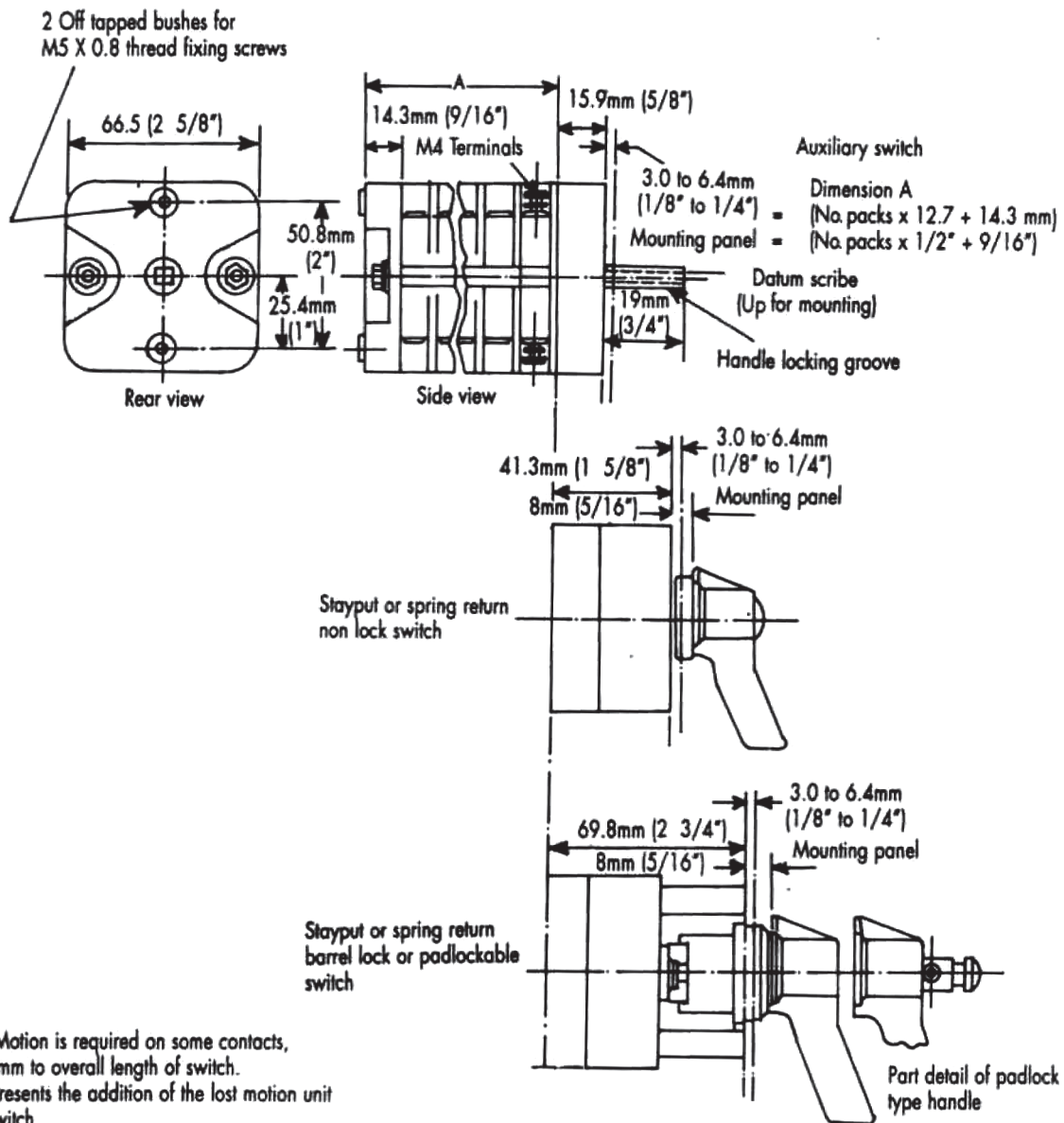

If Lost Motion is required on some contacts, add 54mm to overall length of switch. This represents the addition of the lost motion unit to the switch

Figure 1 :Outline Dimensions

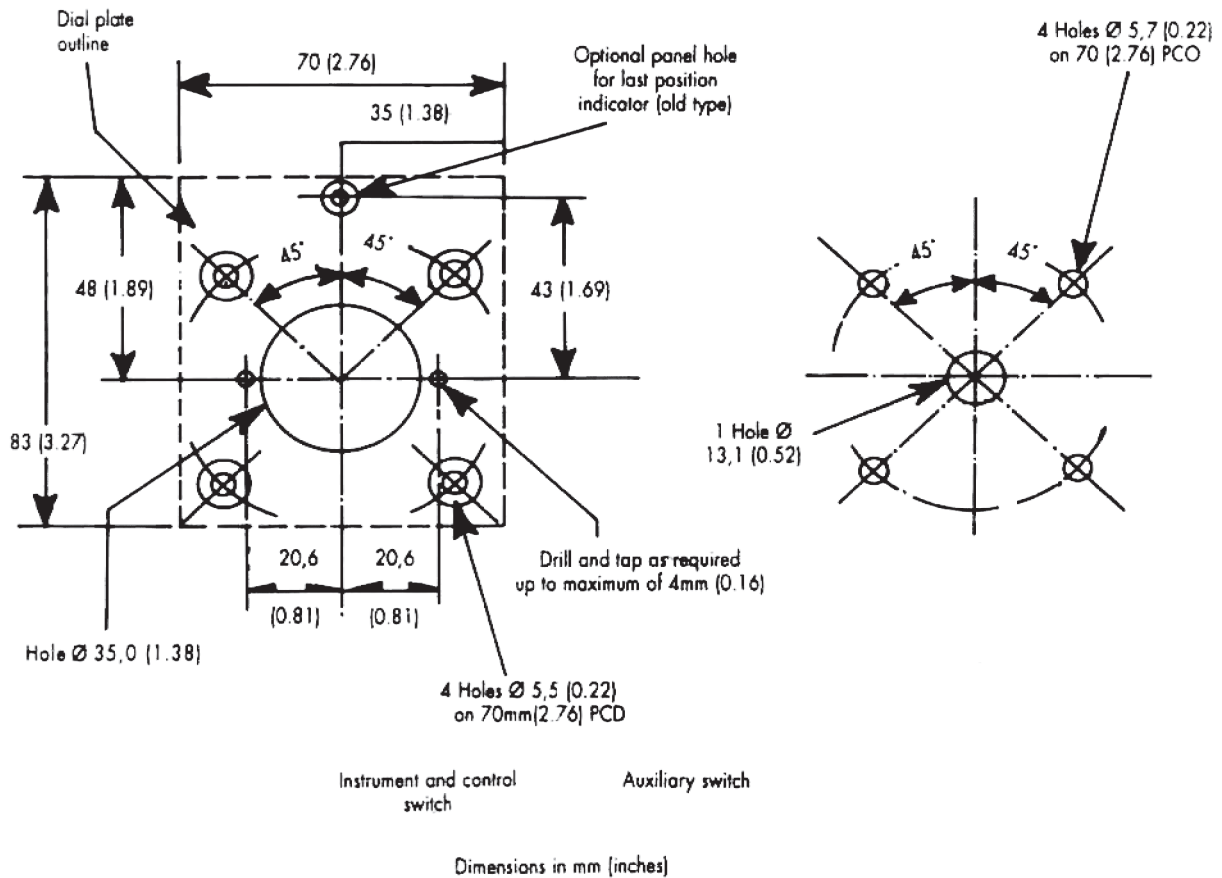

Figure 2 : Panel Drilling Details

Mounting facilities

The switch is suitable for mounting on panels up to a maximum thickness of 6.35 mm by utilizing the four fixings on the front plate equispaced on a 70mm PCD. Panel drilling details included in the illustration.

Enclosures & dust protection

The ODS switch is suitable for use in industrial and power station locations. All switching arts being enclosed and dust protected.

Terminations

The terminal arrangements comprise a 4 mm tin plated brass cheesehead screw suitable for clamping up to 4 mm crimped terminals. Panel Drilling Details

Blow out magnet

Blow out magnets (BOM) are provided on contacts which are used in closing coil circuits of circuit breaker control and for use in vulnerable applications where required. The usage of BOM on contacts increases the break rating.

Escutcheon plate

The escutcheon plate is manufactured from black plain anodised aluminium. Engraving is carried out according to the angular overment of the switch.

Routine tests

All switches are tested for continuity on contact positions and 2 KV RMS withstand test for one minute.

ODS Rotary switch

Electrical rating

Maximum voltage

660 volts ac and dc

Continuous current

All applications 20 amp. ac & dc

Mechanical ratings

3 million switching cycle class IEC 337-1 (1970). Upto 2 million complete rotations of the switch.

Breaking capacity AC

Upto 500,000 operations of 20 A 440V 1Ø 0.3 pf lag.

Upto 1,250,000 operations of 15A 440V 1Ø 0.3 pf lag.

Plus fault test requirements of IEC 337.1 (1970) Category AC11.

Breaking capacity DC

All ratings in table are for 25,000 operations. Plus fault test requirements of IEC 337.1 (1970) Category DC11 for these ratings.

Ordering ODS switches

To assist in the expeditious handling of your enquiries for type ODS switches it is essential that all the necessary information on your requirements is provided with the initial enquiry.

Within our organisation each switch is specified on a .Switch Ordering Sheet' which describes the precise form of the switch being manufactured whether in control or selector form. A copy of this sheet is sent to customer as confirmation of order and to enable drawing work to proceed incorporating the switch within the circuit and equipment for which it is required.

Specimens of those sections of the .Switch Ordering Sheet' of a typical control/selector switch, which the customer is asked to complete are illustrated.

Notes on the information required and the manner of entering the information on the sheets are included.

ODS Switch list number coding

Type	Ways	Lock/Non-lock	Position	Mechanism	Handle	Comb.No
Eg :- ODS	4	N/LF/LT /CS/CP	180	SP	PM	101
I	02-2 way	LF-Lock type	90° - 90° 2 Pos	SP - Stayput		Part Nos. for variables such as contact combination, locking position etc.
L	04-4 way	(Key free)				
L	06-6 way		90° - 90° 3 Pos	SR - Spring return		
U	08-08 way	LT-Locked type	120°-120° 3 Pos	SRS - Spring return		
S	10-10 way	(key trapped)		with sequence		
T	12-12 way	N-Non-Lock	135°-135° 4 Pos	SRSL2 } Spring return		
R	16-16 way	CS-Castel	180°-180° 3 Pos	SRSL4 } with lost motion		
A	20-20 way	Lock 'S' type	180°-180° 5 Pos	Device & 2/4		
T	24-24 way		360° - 360° 8 Pos	bell alarm		
I	30-30 way			contacts		
O						
N		CP-Castel				
		Lock 'P' type		SRSL2 } do with sequence	PM- Pistol grip medium	
				SRSL4 }		

"Alstom logo and any alternative version thereof are trademarks and service marks of Alstom. The other names mentioned, registered or not, are the property of their respective companies. The technical and other data contained in the document are provided for information only. Neither ALSTOM, its officers nor employees accept responsibility for or should be taken as making any representation or warranty (whether express or implied) as to the accuracy or completeness of such data or the achievements of any projected performance criteria where these are indicated. No liability is accepted for any reliance placed upon the information contained in this brochure. Alstom reserves the right to revise or change these data at any time without further notice."

ALSTOM T&D INDIA LIMITED
 Pallavaram Works
 19/1, G.S.T. Road,
 Pallavaram, Chennai - 600 043
 Tel: 91-44-2264 8000
 Fax: 91-44-2264 0040

ALSTOM T&D Worldwide Contact Centre:
<http://www.alstom.com/contactcentre/>
 Tel.: +44 (0) 1785 250 070

www.grid.alstom.com

GRID

