



Smart solutions.  
Strong relationships.

# SF<sub>6</sub>-Gas Circuit Breakers



ISO 14001:2004  
OHSAS 18001:1999  
Integrated Management System

Bureau Veritas  
Certification



ISO 9001

BUREAU VERITAS  
Certification





CG House, Mumbai

## Global Leadership

CG is proud to be a part of the USD 4 billion Avantha Group, a reputed Indian Industrial conglomerate led by its Chairman, Mr. Gautam Thapar. Avantha has business interests in diverse areas, including pulp and paper, power generation, transmission & distribution equipments, solutions & services, food processing, farm forestry, chemicals, energy, infrastructure, information technology (IT) and IT-enabled services.

In keeping with its growing aspirations, Avantha has been aggressively expanding overseas. Avantha has an impressive global footprint and operates in more than 10 countries with over 20,000 employees of 20 nationalities.

As one of the world's leading engineering corporations, CG provides end-to-end solutions, helping its customers use electrical power effectively and increase industrial productivity with sustainability. CG was established in 1937 in India; & since then the Company has been a pioneer & has retained its leadership position in the management and application of electrical energy.

Our unique and diverse portfolio ranges from transformers, switchgear, circuit breakers, network protection & control gear, project engineering, HT & LT motors, drives, lighting, fans, pumps & consumer appliances and turnkey solutions in all these areas; thus enhancing the many aspects of industrial and personal life. This portfolio has been structured into 3 SBUs - Power Systems, Industrial Systems and Consumer Products. For details please refer to the panel on the right.

Since 2005, CG has embarked upon an ambitious globalization strategy, growing both organically and inorganically, drawing into its fold leading international companies such as Pauwels, Ganz, Microsol, Sonomatra, MSE & PTS. Consequent to this globalisation, CG now enjoys manufacturing bases in Belgium, Canada, Hungary, Indonesia, Ireland, France, UK and US, in addition to more than twenty manufacturing locations in India, employing more than 8000 employees worldwide with diverse nationalities and cultures. A worldwide marketing network of more than 150 representatives spans the globe, offering the entire range of CG's products, solutions and services.

Thanks to its well structured and validated business model, CG is well positioned to provide its customers with technology driven, value-added solutions, leveraging a broad product portfolio on the one hand, and enhancing the entire value-chain quality, delivery, and services on the other hand.

CG established its international manufacturing footprint in the year 2005 by acquisition of the Belgium based Pauwels Group which gave CG additional manufacturing facilities for Power & Distribution transformers at Belgium, Ireland, USA, Canada and Indonesia. In its quest to enhance its technology edge, increase its global market reach & expand the product portfolio, CG followed this up with a series of successful acquisitions - Ganz, Hungary in 2006; Microsol, Ireland in 2007; Sonomatra, France in 2008; MSE, USA in 2008, PTS, UK in 2010, and 3 businesses of Nelco, India, in 2010. The business domains of the new companies that joined the CG family, have charted the way for CG progressively entrenching itself globally, as a "full solutions provider" carving out for itself positioning as a serious international player and a recognized transnational corporation. The map below gives an overview of our operations in the countries where we are present.

CG has been aggressively investing in R&D, product certifications, product quality, productivity enhancement and operational excellence. CG's Global R&D centre, located in India, has been recognised for its innovation & received the prestigious "National Award for the Best R&D Efforts" for its outstanding achievements in the Electrical Engineering Sector in 2008. CG's R&D strategy aligns with the Company's Global Vision, & focuses on creating platform technologies, shrinking product development cycle time & enhancing CG's Intellectual Property capital.

To unify our global focus, all CG facilities across the world have taken actions to ensure that customers receive consistent "One World Quality", for all CG products and solutions in all parts of the world.



## Business Edge

The Switchgear Works of Crompton Greaves is located on a 1,32,540 sq.mtrs. plot in Nashik on the Mumbai Agra National Highway and is demarcated in four main divisions: HV & EHV SF<sub>6</sub> Gas Switchgear, HV & EHV Instrument Transformer, Medium Voltage Vacuum Switchgear and Lightning Arresters. Operations commenced in 1980 with the manufacture of Medium Voltage Switchgear, which was relocated from Kanjur Mumbai Works & extended to all range of MV, HV, EHV & UHV Products.

A specialised Business Unit spearheads the export thrust for in-house products as well as carefully out-sourced synergistic products for supply to Trade, Industry, OEMs and Power Utilities.

Our regional establishments throughout India have factory-trained personnel to provide prompt pre & after sales service, supporting our marketing & service personnel located at the factory.



## Introduction

Crompton Greaves Ltd. is one of the leading manufacturers of SF<sub>6</sub> Gas Circuit Breakers in the world. We manufacture Gas Circuit Breakers ranging from 24kV to 800kV.

More than 30,000 Crompton Greaves make SF<sub>6</sub> Gas Circuit Breakers up to 420kV rating have been put into service in various environments in many countries since 1983 where they are operating satisfactorily.

Crompton Greaves has developed 800kV GCB with Spring-Pneumatic Mechanism indigenously with its own R&D efforts. The rating of the GCB is 800kV, 3150A, 50kA.

Crompton Greaves has also developed breakers for -40 Deg application & 60Hz frequency requirement.

Our Manufacturing units systems are certified with ISO 9001, ISO 14001 for environment control & OHSAS 18001.

At Crompton Greaves there is always a passion for quality. A quality trust mark has emerged as Crompton's biggest brand ambassador. In fact, this is reflected through quality certifications for its products and services. Further the commitment to responsible business through quality, technology and productivity.

The company has made considerable progress towards integration of the Six Sigma methodology in its manufacturing processes with the ultimate aim of achieving 'Product Quality as Perceived By Consumer'. This methodology was actively pursued for products for which Critical to Quality (CTQ) characteristics were identified based on market feedback. Regional team has also been trained in Six Sigma technology for capture of customer's voice.

In addition to this, the company has also introduced stringent control measures with suppliers to ensure that inputs support the Six Sigma quality. In fact, all these measures have resulted in manifold

improvement in the CTQs with substantial reduction in defects.

All the SF<sub>6</sub> Gas Circuit Breakers are type tested as per the IEC 62271-100 requirements in various world known testing Laboratories like CESI Italy, KEMA Netherlands, KERI South Korea & CPRI India.

Depending upon the application, type SFM GCBs are divided into two types as follows;

- A) Three phase auto re-closing circuit breaker with one common mechanism for Transformer applications.
- B) Single / Three phase auto re-closing circuit breaker with three separate spring mechanisms (for each phase) for Line applications.

Also these breakers are categorised as per the drive mechanism used for its operation.

The breaker consists of three main parts for its Spring - Spring Mechanism type:

1. Vertical porcelain units containing puffer type interrupter
2. Spring-spring operating mechanism and control equipment in a single housing
3. Base Frame and support columns

The breaker consists of three main parts for its Spring - Pneumatic Mechanism type:

1. Vertical / Horizontal porcelain units containing puffer type interrupter
2. Spring-Pneumatic operating mechanism and control equipment in a single housing
3. Support structure.



SF<sub>6</sub> Breaker 72.5 kV



SF<sub>6</sub> Breaker 36 kV

## SFM Type SF<sub>6</sub> Gas Circuit Breaker (Spring-Spring Mechanism)

Crompton Greaves manufactures SFM type Outdoor SF<sub>6</sub> Gas Circuit Breakers (GCBs) ranging from 72.5kV to 245kV. These GCBs are of live tank design, with motor / manual charged spring-opening spring-closing operating mechanism and are capable of interrupting all possible switching duties. The breakers are single break interrupter design and employ **dual flow puffer action** for current interruption ensuring high operational reliability and safety of power transmission and distribution systems.

The GCBs are capable of clearing the severe rate of rise of recovery voltage due to short line faults and high recovery voltage peak due to out of phase switching. Small currents such as capacitor bank switching current, transformer magnetizing current, cable / line charging current, are interrupted smoothly without any re-strikes or re-ignition and the over-voltages observed are minimum.

## Construction & Operation

Depending upon the application, type SFM GCBs are divided into two types as follows;

Three phase auto re-closing circuit breaker with one common mechanism for Transformer applications.

Single / Three phase auto re-closing circuit breaker with three separate spring mechanisms [for each phase] for Line applications.

The breaker consists of three main parts :

- 1 Vertical porcelain units containing puffer type interrupter.
2. Spring-spring operating mechanism and control equipment in a single housing.
3. Base Frame and support columns.

## The SF<sub>6</sub> GCB Product Features:

- Easy & convenient in installation, fault-detection and operation.
- Proven performance under extreme conditions such as in areas with seismic activity.
- In compliance with the new IEC-62271-100 and ANSI standards.
- Insulation with enhanced creepage distance allows for installation in highly polluted areas without changes in dimensions.
- Highly reliable on account of simple design and proven technology.
- Robust construction with easy-to-access mechanisms.
- Type tested at recognised international laboratories- CESI Italy, KERI Korea, KEMA Netherlands.
- All range of Circuit Breakers is certified to achieve C2 & M2 class as per IEC 62271-100.
- Leader in domestic market.
- Widely exported to Italy, USA, Brazil, Chile, South Africa and other countries.



## SF<sub>6</sub>-Gas Circuit Breakers (GCB)

For Out-Door Use From (24 kV To 800 kV)

CGL is the only manufacturer in India for supply of 420kV SF<sub>6</sub> Circuit Breakers to meet the high altitude requirement of 1600m.

The SF<sub>6</sub> Gas Circuit Breaker (GCB) Products range is as follow:

- 1) Medium Voltage Gas Circuit Breaker (MV GCB)
  - a) 36kV outdoor type upto 3150A , 40kA.
  - b) 36kV Indoor type upto 2000A, 40kA.
- 2) High Voltage Gas Circuit Breaker (HV GCB)
  - a) 72.5kV outdoor type upto 3150A, 40kA.
  - b) 145kV outdoor type upto 3150A, 40kA.
  - c) 170kV outdoor type upto 3150A, 40kA.
- 3) Extra High Voltage Gas Circuit Breaker (EHV GCB)
  - a) 245kV Outdoor Type upto 3150A, 40kA.
  - b) 420kV Outdoor type upto 3150A, 50kA.
- 4) Ultra High Voltage Gas Circuit Breaker (UHV GCB)
  - a) 800kV Outdoor type upto 3150A, 50kA.



SF<sub>6</sub> Breaker 800 kV

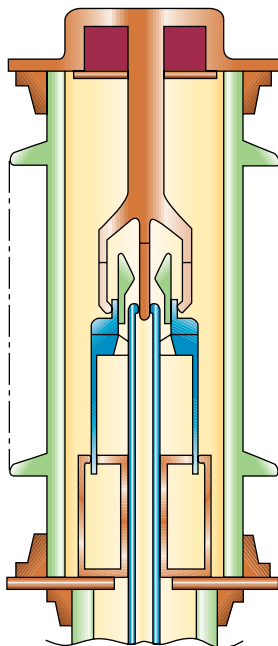

FIG. 1 : Closed position

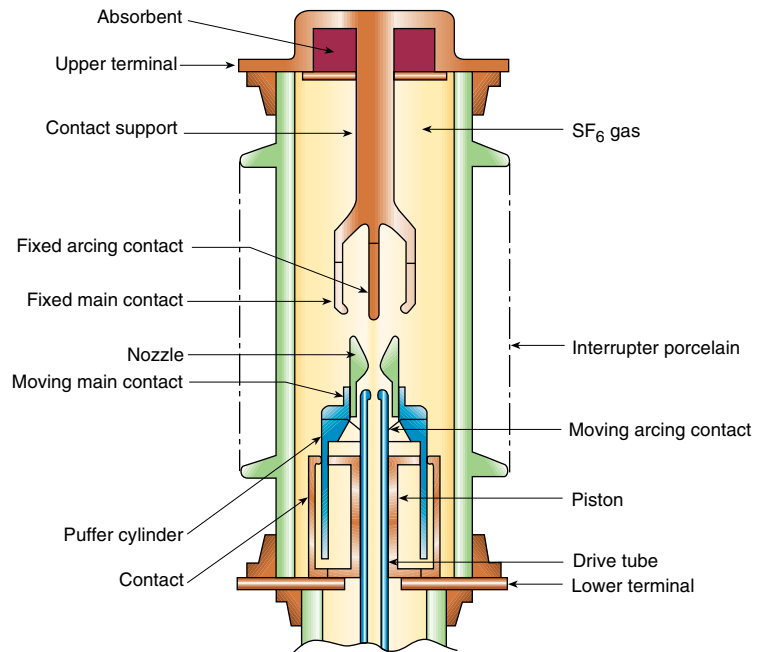

FIG. 2 : Open position

- Key**
- Live parts (moving parts)
  - Live parts (fixed parts)
  - Insulators
  - SF<sub>6</sub> gas

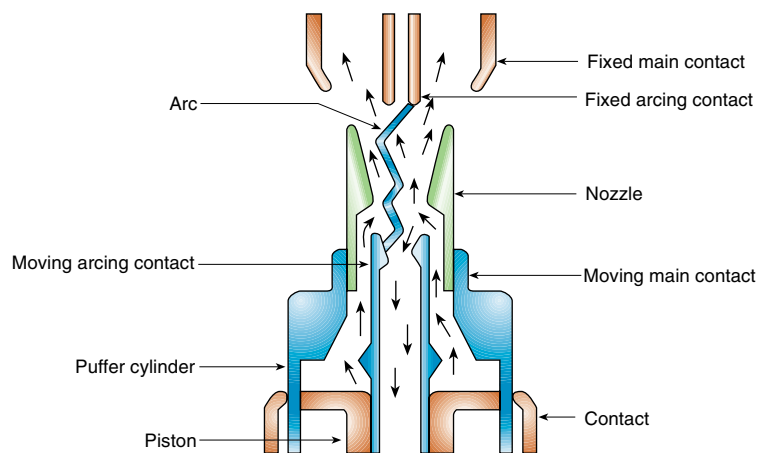

FIG. 3 : Interrupting principle

## INTERRUPTER

### Interrupting Unit of SF<sub>6</sub> Gas Circuit Breaker Working Principle:

The interrupting unit filled with pressurized SF<sub>6</sub> gas is placed at the top of the pole and contains Stationary Contact, Nozzle, Moving Contact, Puffer Cylinder and Fixed Piston (Fig.1). During opening operation (Fig.2), the Moving Contact along with the Puffer Cylinder is pulled down. The Fixed and Moving contacts get separated and arc is formed between fixed arcing contact

and moving arcing contact. Motion of the Puffer Cylinder compresses SF<sub>6</sub> gas against the Fixed Piston thus generating a powerful SF<sub>6</sub> gas blast through the Nozzle over the arc. After travelling through some distance, the dielectric strength of the gap is raised sufficiently to extinguish the arc. The reliability of the system is further enhanced by the single pressure dual flow puffer interrupter, which reduces the number of moving parts and auxiliary systems in the circuit breaker. This principle is shown in Fig. 3.

## Working Principle : Arc Assist Interrupters

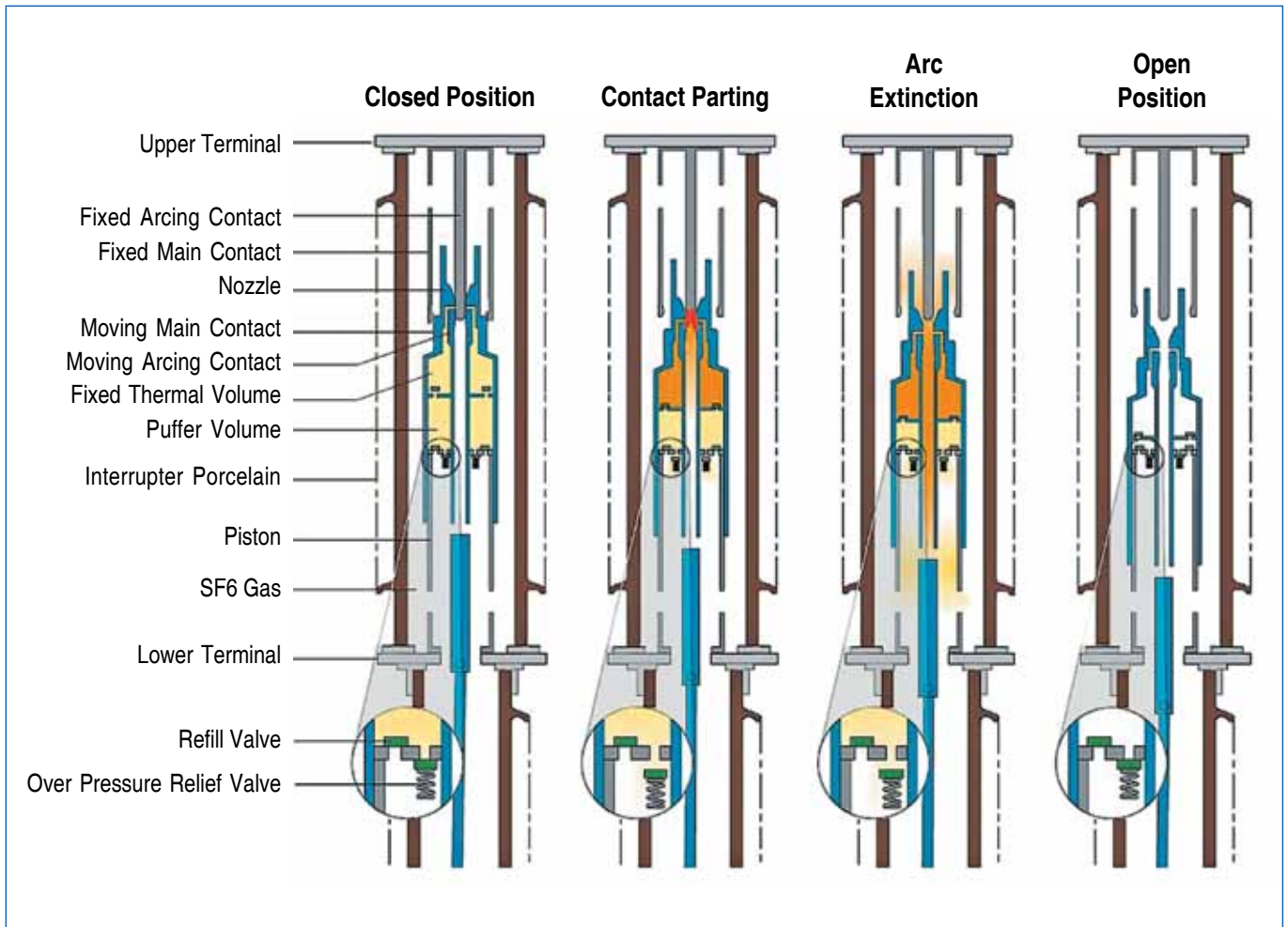

The interrupting unit filled with pressurised SF<sub>6</sub> gas is placed at the top of the pole and contains Stationary contact, Nozzle, Moving Contact, Fixed thermal volume, Puffer Cylinder, Fixed piston. During opening operation, the moving contact along with fixed thermal volume and puffer cylinder is pulled down.

The fixed and moving contacts get separated and arc is formed between fixed arcing contact and moving arcing contact. The arc radiates heat and begin to heat the SF<sub>6</sub> gas in fixed thermal volume, which increases the gas pressure inside the thermal volume. At the same time the Puffer pressure increases and released through the over pressure relief valve. Hence there is no need for high operating energy to overcome the compression of SF<sub>6</sub> gas.

When the current waveform crosses the zero, the arc becomes relatively weak. At this point, the pressurised SF<sub>6</sub> gas flows from fixed thermal volume through the nozzle to the Arc zone and extinguishes the arc. In full open position, there is sufficient distance between fixed and moving contacts to withstand rated dielectric levels.

At closing, the refilling valve opens and gas gets filled into puffer and fixed thermal volume.

When interrupting low currents, the arc energy is not sufficient to heat the gas in fixed thermal volume. Hence this interrupter act in same way as puffer interrupters.

## SF<sub>6</sub>-Gas Circuit Breakers (GCB)



Spring - Spring Operating Mechanism

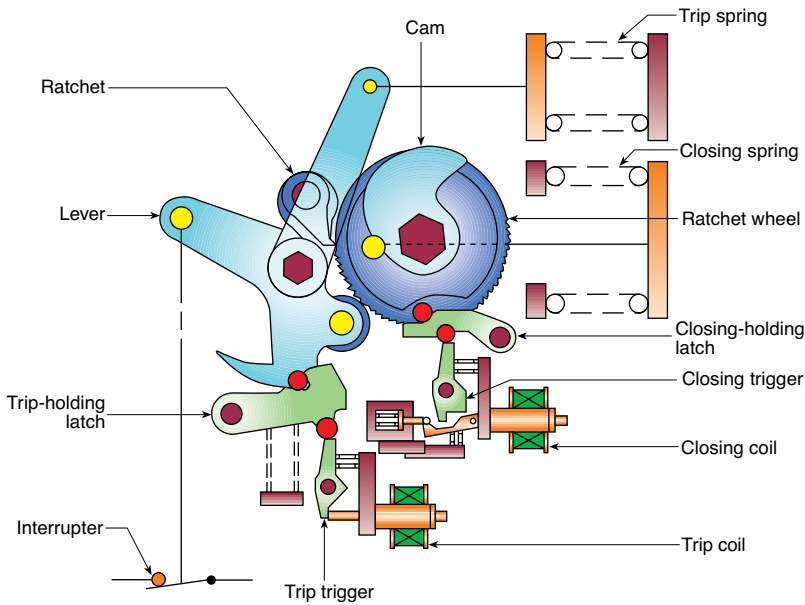

FIG. 4 : Closed position (closing spring charged)

The spring-spring mechanism consists of two springs – Closing spring and Tripping spring. Closing spring is charged through a motor driven cam, pawl and ratchet mechanism.

Fig.4 shows the Breaker in Closed position (Closing spring charged)

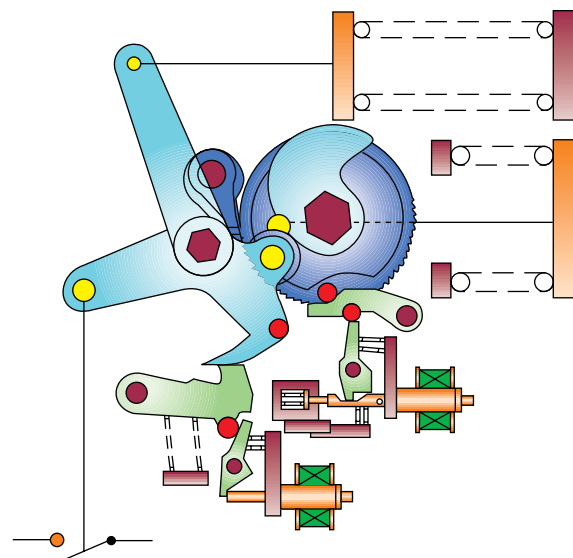

FIG. 5 : Open position (closing spring charged)

Both closing spring and tripping spring are in charged position. The Tripping spring exerts counter clockwise torque on the lever. At this stage a locking device called 'Trip Holding Latch' avoids lever movement. When the trip coil is energized, the lever is released from locking device and rotates to attain the 'Open' position.

Fig.5 shows the Breaker in Open position

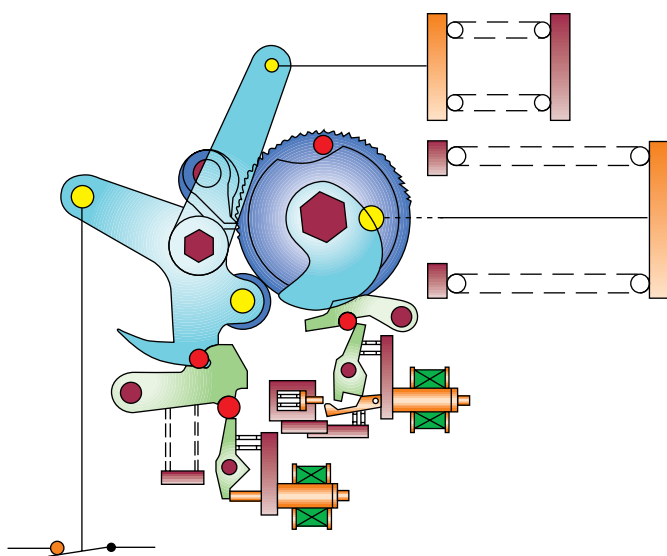
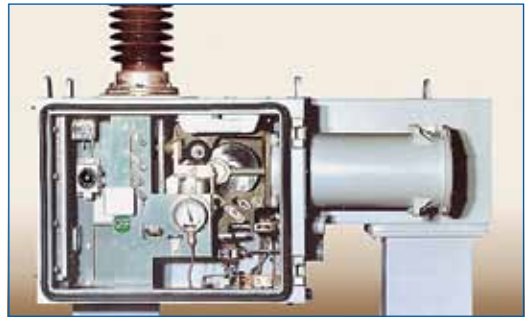
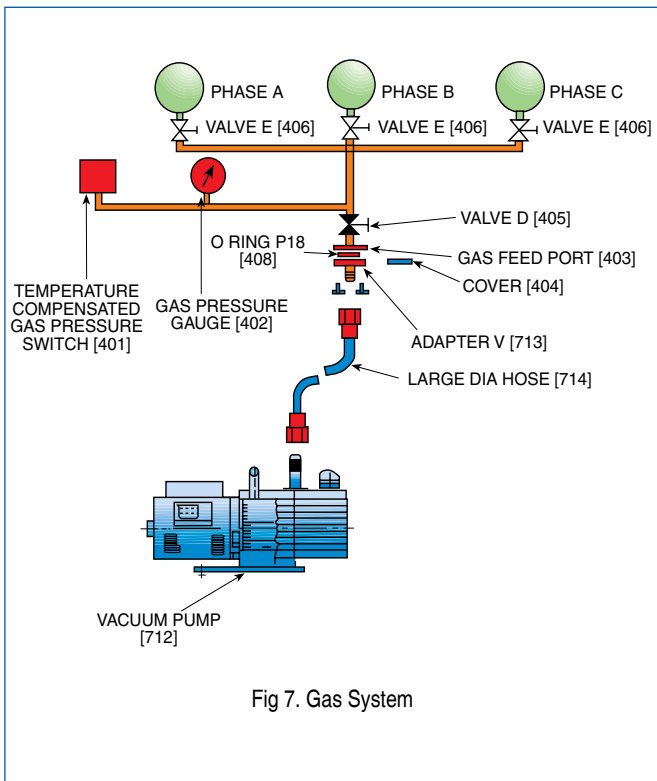

FIG. 6 : Closed position (closing spring discharged)

Tripping spring is in the relaxed condition. Closing spring exerts counter clockwise torque on the Cam and Ratchet wheel. When the Closing coil is energized, the Cam rotates in counter clockwise direction and in turn, the Lever is rotated clockwise. This lever motion closes the breaker and charges the Tripping spring at the same time.

Fig.6 shows Closed position ( Closing spring discharged )

Immediately after the breaker is closed, the spring charging motor gets activated. The closing spring is charged by the ratchet, linked to the motor. When the closing spring is fully charged the Limit Switch disconnects the supply to the motor and the closing-holding latch holds the compressed spring energy till next discharge.



Spring Mechanism 145kV - Closing Spring

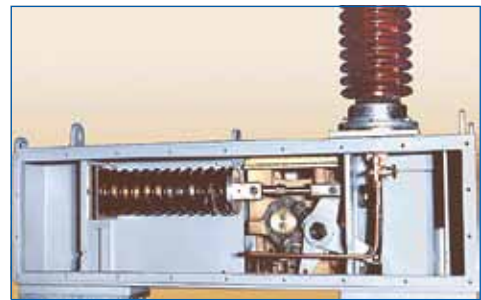

Spring Mechanism 145kV - Opening Spring (Rear View)

## Gas System (Refer Fig. 7)

The gas within the pole units is connected through pipes to form a gas system which is monitored by a Gas Pressure Gauge (402) and a Temperature-compensated Gas Pressure Switch (401) located in the mechanism housing. The gas system also provides a Gas Valve

E (406) for shutting of the gauge (402) and switch (401) from the breaker as to permit their inspection and maintenance Gas Valve D (405) also located in the mechanism housing is provided for gas filling or evacuation of the breaker during installation or maintenance.



# SF<sub>6</sub>-Gas Circuit Breakers (GCB)



## Quality

Quality of the final products are ensured right at the Component manufacturing stage, Through,

- Six sigma methodology for improving product quality as perceived by customer
- Model Cell Concept (factory within factory)
- World class test setup
- Structured Policy for supplier quality

## Routine Testing

All routine tests as specified in IEC, are conducted on the fully assembled GCBs at our factory. In addition to the specified tests as per IEC, the following tests are also carried out on each breaker.

For all Spring Spring & Spring Pneumatic Breakers.

- MECHANICAL OPERATION TESTS
- ELECTRICAL SEQUENCE TEST (CONTROL & AUXILIARY CIRCUIT CHECK)
- MEASUREMENT OF SPEED & TIME (NO LOAD OPERATING CHARACTERISTICS)
- DCRM TEST as per Customer requirement.
- MILLI VOLT DROP TEST (CONTACT RESISTANCE MEASUREMENT)
- HIGH VOLTAGE TEST ON MAIN CIRCUIT
- HIGH VOLTAGE TEST ON CONTROL & AUXILIARY CIRCUIT
- GAS LEAKAGE TESTS
- GAS DENSITY SWITCH OPERATION TESTS
- MEASUREMENT OF TRIPPING & CLOSING COIL RESISTANCE

In addition to all above tests following tests are performed on Spring Pneumatic Breakers.

- REPLENISHING TIME MEASUREMENT FOR COMPRESSED AIR
- AIR PRESSURE SWITCHES OPERATION
- SAFETY VALVE OPERATION
- AIR LEAKAGE TEST

CGL testing laboratory is fully equipped with the latest testing equipment viz:

- 700 kV Test Transformer

- PD Measurement up to 100kV
- High precision mass Spectrometer Type Gas Leak Detector (with capability to detect leaks as low as 1 ppm).
- Multi-Channel Breaker Speed / Time Analysers.
- Mechanical Endurance Controller
- Contact Resistance Meter (Static)
- Dynamic Contact Resistance (Signature)
- Primary Injection Test Set.

Full testing before despatch of breaker ensures trouble free operation at site and complete customer satisfaction

## Fabrication & Surface Treatment

All critical components & sheet metal stamping are manufactured on CNC machines ensuring high dimensional consistency. All parts coming in contact with moisture are zinc plated and passivated. All exposed ferrous parts are treated to give high corrosion resistance. They are shot blasted, zinc sprayed, epoxy primer coated and finally painted with polyurethane aliphatic based paint ensuring excellent finish & corrosion protection. All joints are secured against loosening by using torque wrenches & other suitable means. All exposed hardware are of Stainless Steel or Hot Dip Galvanised for outdoor GCBs.

## Transport & Site Installation

All the Circuit Breakers are factory tested and then depending on the type involved are partly dismantled into packing units which are dispatched. All the sub-assemblies are individually wrapped to reduce the harmful effects of atmosphere. For Exports, the breakers are dispatched with Sea Worthy Packing. The Circuit Breaker Poles are filled with a small quantity of SF<sub>6</sub> Gas for Transportation (at a guage pressure of 0.5 kg/cm<sup>2</sup>) to avoid moisture ingress and evacuation at site. Site installation is simple and no site adjustments are required during Erection and Commissioning, all main adjustments / settings are done in the factory prior to delivery.

## Customer Support & After Sales Service

We provide solutions to all possible Technical requirements to Customer through our highly qualified Engineers having rich experience in the field. Our Service Engineers, Technicians and Authorised Representatives can provide services supervision of Erection and Commissioning and After Sales Service at site.

## Guaranteed Technical Particulars

### 24kV - 72.5kV SF<sub>6</sub> Gas Circuit Breaker [Spring - Spring Mechanism]

SN	DESCRIPTION	UNITS	(3 PHASE AUTO RE-CLOSING)					(1 PHASE AUTO RE-CLOSING)		
1.	TYPE REFERENCE	-	20-SFGP-25A	30-SFGP-25A	30-SFGP-40A	70-SFM-32B	70-SFM-40AA	70-SFM-32B	50-SFGP-20A*	30-SFGP-25A*
2.	RATED VOLTAGE	kV	24	36	36	72.5	72.5	72.5	25KV GCB (52KV CLASS)	25KV INT. (52KV CLASS)
3.	RATED LIGHTNING IMPULSE WITHSTAND	kVp	150	200	200	350	350	350	250	250
4.	RATED POWER FREQUENCY WITHSTAND	kV	60	80	80	160	160	160	95	95
5.	CREEPAGE DISTANCE [TOTAL]	mm	600	900	900	1815	1815	1815	1300	1300
6.	APPLICABLE STANDARDS	-	IEC-62271-100 / IS 13118					IEC 62271-100 / RDSO Spec.		
7.	TYPE OF MECHANISM	-	SPRING-SPRING							
8.	RATED NORMAL CURRENT	A	1250 / 1600 / 2000			3150		3150	1600	800
9.	RATED OPERATING SEQUENCE	-	O - 0.3sec - CO - 3min - CO/CO - 15sec - CO							
10.	RATED FREQUENCY	Hz	50 / 60					50 / 60	50	
11.	RATED DURATION OF SHORT CIRCUIT	sec.	3							
12.	RATED CLOSING/TRIPPING VOLTAGE	V DC	110/125/220						110	
13.	CURRENT OF CLOSING/TRIPPING COIL	A	6A MAX. AT 110 V DC							
14.	RATED BREAK TIME	<=mS	80			60	60	60	65	80
15.	RATED CLOSING TIME	<=mS	100			130	80	130	100	
16.	RATED SHORT CIRCUIT BREAKING CURRENT	kA	25	25	40	31.5	40	31.5	20	8
17.	RATED SHORT CIRCUIT MAKING CURRENT	kAp	62.5		100	80	100	80	50	20
19.	RATED CABLE CHARGING BREAKING CURRENT AND OVER VOLTAGE	A / pu	50 / < 2.5			250/<2.5	125/<2.5	250/<2.5	—	—
20.	RATED SINGLE CAPACITOR BANK BREAKING CURRENT & OVER VOLTAGE	A / pu	400/<2.5		400/<2.5	600/<2.5	400/<2.5	600/<2.5	440 / < 2.5	440 / < 2.5
21.	RATED OUT OF PHASE BREAKING CURRENT	kA	6.25	6.25	10	7.9	10	7.9	—	—
22.	FIRST POLE TO CLEAR FACTOR	-	1.5					1.5	—	—
23.	AUXILIARY CONTACTS	-	5 NO + 5 NC			8 NO + 8 NC		8 NO + 8 NC	6 NO + 6 NC	
24.	SF6 GAS PRESSURE [ AT 20deg C]									
	- NORMAL	Kg/cm <sup>2</sup>	5		6	5	6		5	
	- GAS FEED ALARM	Kg/cm <sup>2</sup>	4.5		5.5	4.5	5.5		4.5	
	- LOCKOUT	Kg/cm <sup>2</sup>	4		5	4	5		4	
25.	DIMENSIONS									
	A	mm	600	750	750	1100	1100	3000**	—	—
	B	mm	2783	3103	3103	3070	3525	3070	3533	3533
	H	mm	3349	3819	3819	3998	4574	3998	4579	4249
26.	WEIGHT [ APPROX ]	Kg	675	780	750	1100	820	2100	500	500

Standard Altitude 1000m

\* For Railway application, \*\*Adjustable

## Optionals

SN	DESCRIPTION	UNITS	(3 PHASE AUTO RE-CLOSING)	(1 PHASE AUTO RE-CLOSING)
1.	CREEPAGE DISTANCE	mm / kV	31	—
2.	CLOSING / TRIPPING COIL VOLTAGE	V DC	48 / 60 / 110 / 125 / 220	—
3.	CLEARANCE OF LIVE PARTS TO GROUND	-	AS PER CUSTOMER SPECIFICATIONS	—
4.	MAX. ALTITUDE ABOVE SEA LEVEL	m	2200	—
5.	AUXILIARY CONTACTS	-	10 NO + 10 NC	—
6.	SEISMIC ACCELERATION	g	0.3 / 0.4	—

## Guaranteed Technical Particulars

### 110kV - 245kV SF<sub>6</sub> Gas Circuit Breaker [Spring - Spring Mechanism]

SN	DESCRIPTION	UNITS	(3 PHASE AUTO RE-CLOSING)				(1 PHASE AUTO RE-CLOSING)			
1.	TYPE REFERENCE	: -	120-SFM-32B	120-SFM-32B	120-SFM-32B	150-SFM-40B	120-SFM-32B	120-SFM-32B	120-SFM-32B	150-SFM-40B
2.	RATED VOLTAGE	: kV	123	145	145	170	123	145	145	170
3.	RATED LIGHTNING IMPULSE WITHSTAND	: kVp	550	650	650	750	550	650	650	750
4.	RATED POWER FREQUENCY WITHSTAND	: kV	230	275	275	325	230	275	275	325
5.	CREEPAGE DISTANCE [TOTAL]	: mm	3075	3625	3625	4250	3075	3625	3625	4250
6.	APPLICABLE STANDARDS	: -	IEC-62271-100 / IS 13118							
7.	TYPE OF MECHANISM	: -	SPRING-SPRING							
8.	RATED NORMAL CURRENT	: A	3150							
9.	RATED OPERATING SEQUENCE	: -	O - 0.3sec - CO - 3min - CO/CO - 15sec - CO							
10.	RATED FREQUENCY	: Hz	50/60							
11.	RATED DURATION OF SHORT CIRCUIT	: sec.	3							
12.	RATED CLOSING/TRIPPING VOLTAGE	: V DC	110/125/220							
13.	CURRENT OF CLOSING/TRIPPING COIL	: A	6A MAX. AT 110 V DC							
14.	RATED BREAK TIME	: mS	60							
15.	RATED CLOSING TIME	: mS	130		100		130			100
16.	RATED SHORT CIRCUIT BREAKING CURRENT	: kA	31.5		40		31.5			40
17.	RATED SHORT CIRCUIT MAKING CURRENT	: kAp	80		100		80			100
18.	RATED LINE CHARGING BREAKING CURRENT AND OVER VOLTAGE	: A / pu	50/<2.5				50/<2.5			
19.	RATED CABLE CHARGING BREAKING CURRENT AND OVER VOLTAGE	: A / pu	160/400/<2.5		160/<2.5		160/400/<2.5		160/<2.5	
20.	RATED SINGLE CAPACITOR BANK BREAKING CURRENT AND OVER VOLTAGE	: A / pu	400/<2.5				400/<2.5			
21.	RATED OUT OF PHASE BREAKING CURRENT	: kA	7.9		10		7.9			10
22.	FIRST POLE TO CLEAR FACTOR	: -	1.5				1.5			
23.	AUXILLIARY CONTACTS	: -	8 NO + 8 NC				8 NO+8 NC			
24.	SF6 GAS PRESSURE [ AT 20deg C]									
	- NORMAL	: Kg/cm <sup>2</sup>	6		7		6			7
	- GAS FEED ALARM	: Kg/cm <sup>2</sup>	5.5		6.5		5.5			6.5
	- LOCKOUT	: Kg/cm <sup>2</sup>	5		6		5			6
25.	DIMENSIONS									
	A	: mm	1700	1700	1700	2200	3000**	3000**	3000**	3000**
	B	: mm	4010	4010	4010	4310	4010	4010	4010	4010
	H	: mm	5388	5388	5548	6089	5388	5388	5548	5776
26.	WEIGHT [ APPROX ]	: Kg	1450	1450	1550	2200	2360	2460	2550	3300

Standard Altitude 1000m

\*\*Adjustable

## Optionals

SN	DESCRIPTION	UNITS	(3 PHASE AUTO RE-CLOSING)		(1 PHASE AUTO RE-CLOSING)	
1.	CREEPAGE DISTANCE	mm / kV	31			
2.	CLOSING / TRIPPING COIL VOLTAGE	V DC	110/125/220			
3.	CLEARANCE OF LIVE PARTS TO GROUND	-	AS PER CUSTOMER SPECIFICATIONS			
4.	MAX. ALTITUDE ABOVE SEA LEVEL	m	1600		1600	
5.	AUXILLIARY CONTACTS	-	10 NO + 10 NC			
6.	SEISMIC ACCELERATION	g	0.3 / 0.4			

## Guaranteed Technical Particulars

### 245kV - 800kV SF<sub>6</sub> Gas Circuit Breaker [ Spring - Spring Mechanism ]

SN	DESCRIPTION	UNITS	(1 PHASE AUTO RE-CLOSING)		
1.	TYPE REFERENCE	: -	200-SFM-40S	400-SFM-50AA	800-SFM-50AA
2.	RATED VOLTAGE	: kV	245	420	800
3.	RATED LIGHTNING IMPULSE WITHSTAND	: kVp	1050	1425	2100
4.	RATED POWER FREQUENCY WITHSTAND	: kV	460	520/610	870/960
5.	CREEPAGE DISTANCE [TOTAL]	: mm	6125	10500	20000
6.	APPLICABLE STANDARDS	: -	IEC-62271-100 / IS 13118		
7.	TYPE OF MECHANISM	: -	Spring-Spring		
8.	RATED NORMAL CURRENT	: A	3150		
9.	RATED OPERATING SEQUENCE	: -	O. - 0.3 sec. - CO - 3 min. - CO/CO - 15 sec. - CO		
10.	RATED FREQUENCY	: Hz	50 / 60		
11.	RATED DURATION OF SHORT CIRCUIT	: sec.	3		
12.	RATED CLOSING/TRIPPING VOLTAGE	: V DC	110/125/220	220	
13.	CURRENT OF CLOSING/TRIPPING COIL	: A	6A MAX. AT 110VDC		
14.	RATED BREAK TIME	: mS	60	45	
15.	RATED CLOSING TIME	: mS	150	100	
16.	RATED SHORT CIRCUIT BREAKING CURRENT	: kA	40	50	
17.	RATED SHORT CIRCUIT MAKING	: kAp	100	125	
18.	RATED LINE CHARGING BREAKING	: A/pu	125/<2.5	400/<2.5	900/<2.5
19.	RATED CABLE CHARGING BREAKING CURRENT AND OVER VOLTAGE	: A / pu	250/<2.5	400/<2.5	—
20.	RATED SINGLE CAPACITOR BANK BREAKING CURRENT & OVER VOLTAGE	: A / pu	400/<2.5	400/<2.5	—
21.	RATED OUT OF PHASE BREAKING CURRENT	: kA	10	12.5	
22.	FIRST POLE TO CLEAR FACTOR	: -	1.3		
23.	AUXILIARY CONTACTS	: -	8 NO + 8 NC		
24.	SF6 GAS PRESSURE [ AT 20deg C ]				
	- NORMAL	: Kg/cm <sup>2</sup>	7	7	7
	- GAS FEED ALARM	: Kg/cm <sup>2</sup>	6.5	6.5	6.5
	- LOCKOUT	: Kg/cm <sup>2</sup>	6	6	6
25.	DIMENSIONS				
	A	: mm	4500	7000**	10000*
	B	: mm	4605	6586	8712
	H (WITHOUT CLOSING RESISTOR)	: mm	7165	6800	8926
	H (WITH CLOSING RESISTOR)	: mm	—	7330	9456
26.	WEIGHT [ APPROX ]				
	WITHOUT CLOSING RESISTOR	: kg.	3775	7500	19300
	WITH CLOSING RESISTOR	: kg.	—	9800	22600

Standard Altitude 1000m

\*\*Adjustable

## Optionals

SN	DESCRIPTION	UNITS	(1 PHASE AUTO RE-CLOSING)		
1.	CREEPAGE DISTANCE	mm / kV	31		
2.	CLOSING / TRIPPING COIL VOLTAGE	V DC	110/125/220		
3.	CLEARANCE OF LIVE PARTS TO GROUND	-	AS PER CUSTOMER SPECIFICATIONS		
4.	MAX. ALTITUDE ABOVE SEA LEVEL	m	2000	1600	—
5.	AUXILIARY CONTACTS	-	10 NO + 10 NC		
6.	SEISMIC ACCELERATION	g	0.3 / 0.4		
7.	RATED CURRENT	A	4500		

## Dimensional Details

<p><b>25kV INT/GCB Single Phase Auto Reclosing Breaker</b></p>	<p><b>Foundation Plan Details</b></p>
<p><b>24/36kV Three Phase Auto Reclosing Breaker</b></p>	<p><b>Foundation Plan Details</b></p>
<p><b>72.5kV Three Phase Auto Reclosing Breaker</b></p>	<p><b>Foundation Plan Details</b></p>
<p><b>110/145kV Three Phase Auto Reclosing Breaker</b></p>	<p><b>Foundation Plan Details</b></p>

## Dimensional Details

### 110kV / 145kV Single Phase Auto Reclosing Breaker

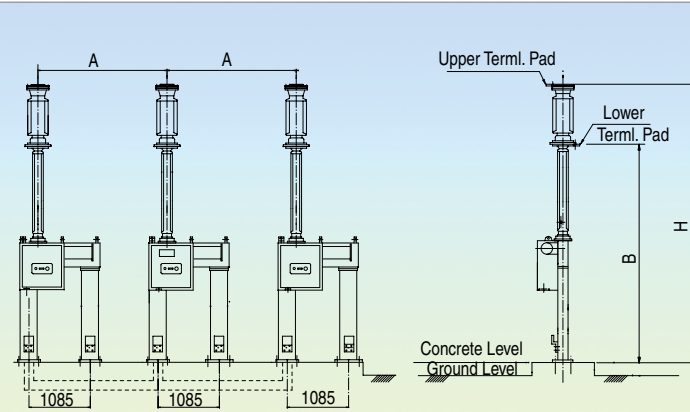

### Foundation Plan Details

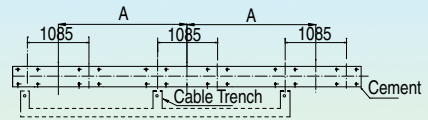

### 170kV Three Phase Auto Reclosing Breaker

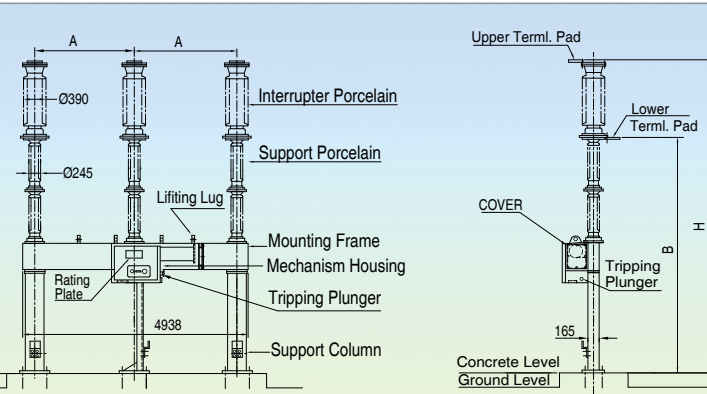

### Foundation Plan Details

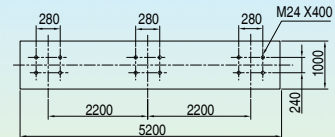

### 170kV Single Phase Auto Reclosing Breaker

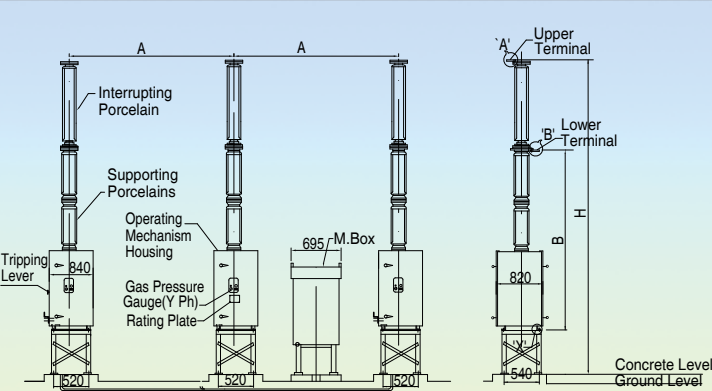

### Foundation Plan Details

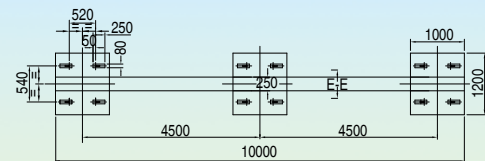

### 245kV Single Phase Auto Reclosing Breaker

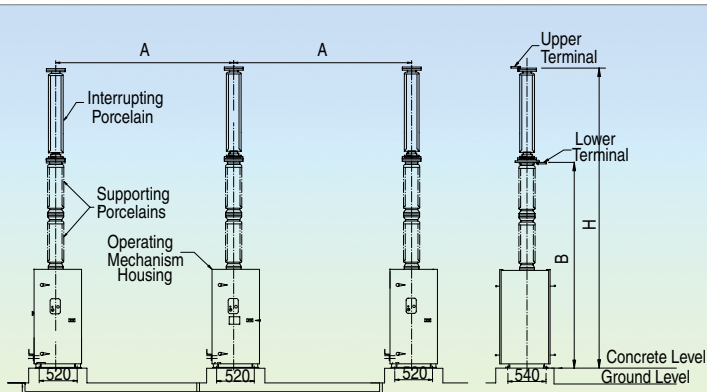

### Foundation Plan Details

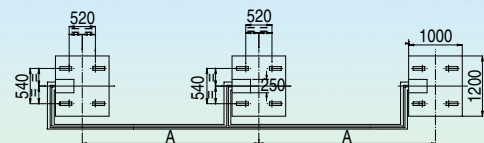

## Dimensional Details

### 420kV Single Phase Auto Reclosing Breaker

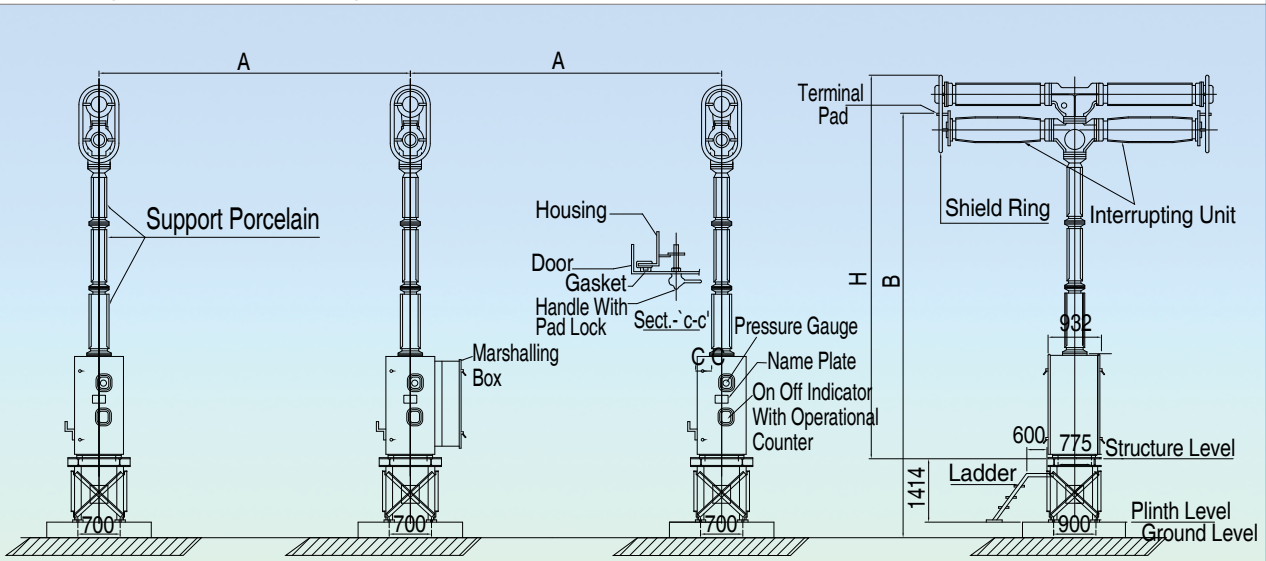

### Foundation Plan Details

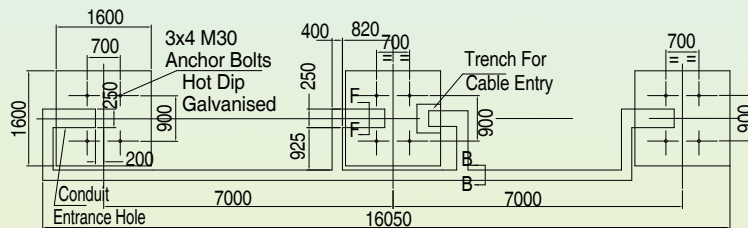

### 800kV Single Phase Auto Reclosing Breaker

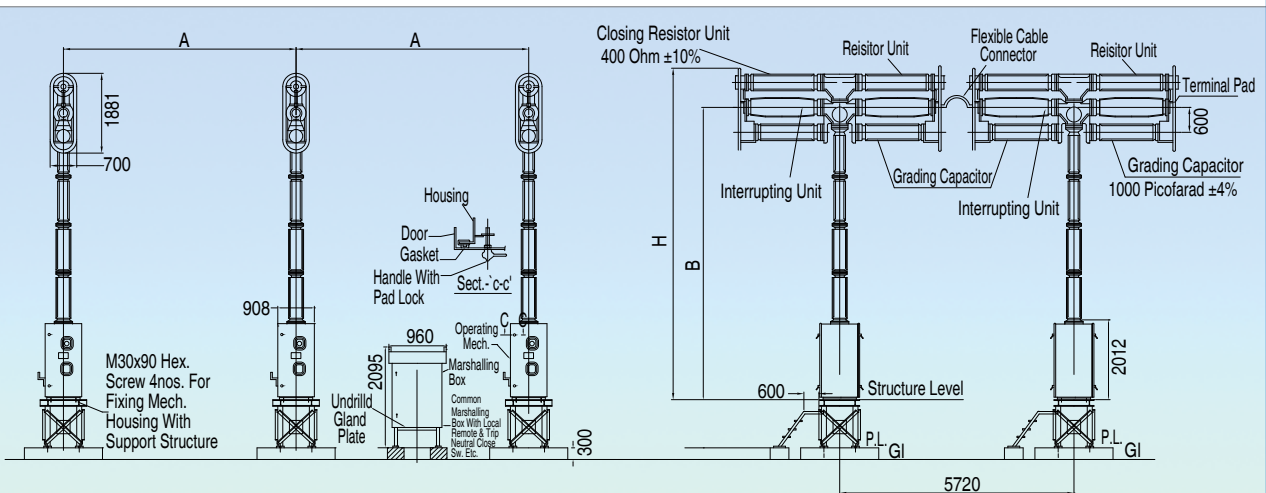

### Foundation Plan Details

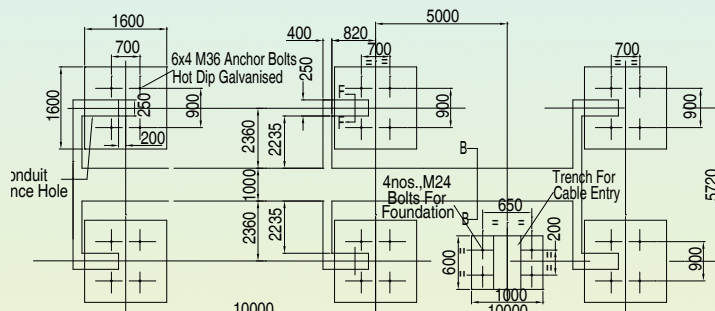

### Switchgear Poem

There occurs a fault  
Then the current should halt  
Otherwise the fault current will increase  
& the service continuity decrease

But the relay acts quick  
& the CIRCUIT BREAKER trips

The faulty part is disconnected  
& the power system is protected

Thank you Mr. SWITCHGEAR  
Because of you there is little fear !!



### Our Major Customers :

#### International Customers :

ENDESA - Spain; ENEL, TERNA - Italy; KEPCO - Korea; TNB - Malaysia; TPC - Taiwan; CEB - Sri Lanka; NPPMB, CPPMB, SPPMB, HCMCPC, PC1, PC2, PC3, PTC4 - Vietnam; PGCB, REB, DESA, BPDB - Bangladesh; NPC Transco - Philippines; TXU, ERGON, AGL, POWERCOR, ETSA, TRANSGRID, INTEGRAL, ENERGEX - Australia; ZESA - Zimbabwe; NEPA - Nigeria; PEDEEE, PEEGT - Syria; KWPA, HREC, KHREC - Iran; EPE - Argentina; PT PLN - Indonesia; PEA, EGAT - Thailand; ESKOM, SPOORNET - South Africa; VRA, ECG - Ghana; KPLC - Kenya; AMPLA, COELCE, ELEC NOR, COPEL, ELETROSUL, RGE - Brazil; EDELNOR, ELECTROSUR - Peru; Chilectra, EMEL, EFE - Chile; EDENOR, EDESUR, SECHEEP, EPE, TRANSBA - Argentina

SIEMENS - Germany, Thailand, Indonesia, Bangladesh, Turkey, India.

AREVA - Indonesia, Singapore, Australia.

ABB - Norway, Turkey.

HYOSUNG; LG; HYUNDAI HEAVY IND; HYUNDAI ENGG;

HYUNDAI CONST - Korea.

TRAFO - Brazil

CONCO - South Africa.

#### Domestic Customers:

POWERGRID, NTPC, NHPC, REL

Indian RAILWAYS, DMRC,

TNEB, APTRANSCO, APGENCO, KPTCL, KSEB

WBSETCL, DVC, JSEB, ASEB, CESC. OPTCL.

GETCO, GSECL, MSETCL, MPPGCL, MPPTCL, CSEB,

RRVPLN, UPPCL, PSEB, HVPNL, DTL, UPPTCL, UPCL.

J&K GPDD.

All Major EPC Contractors like L&T, EMCO, SIEMENS, ABB, AREVA, IRCON, JSL etc. All Industrial Customers.

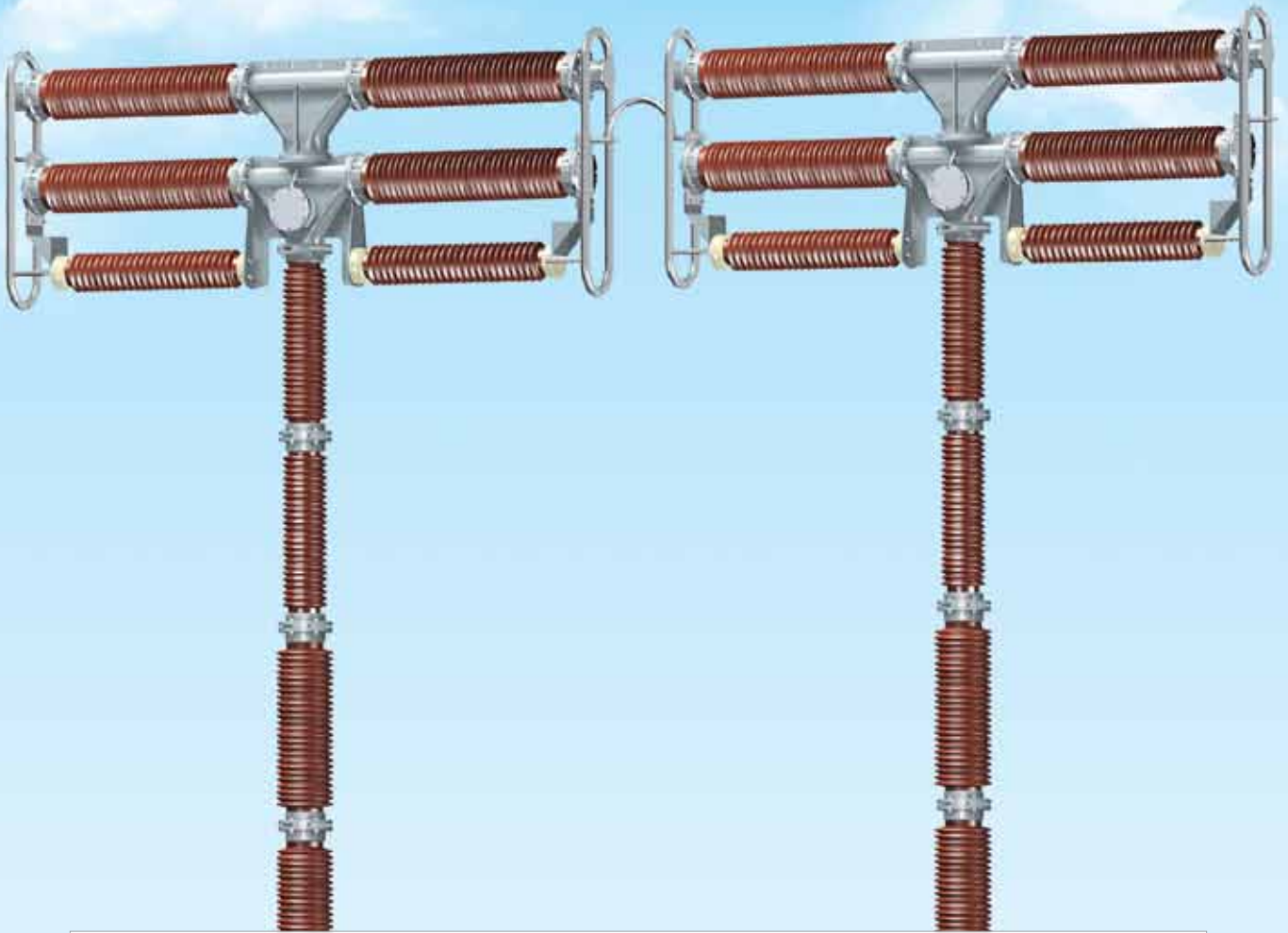

## GLOBAL PRESENCE

- Australia
- Argentina
- Bangladesh
- Benin
- Brazil
- Botswana
- Chile
- Costa Rica
- Colombia
- Canada
- U.A.E.
- Ethiopia
- Ecuador
- Egypt
- France
- Greece
- Ghana
- Indonesia
- Iraq
- Iran
- Italy
- Iceland
- Jordan
- Japan
- Kenya
- Kyrgyzstan
- Laos
- Mauritania
- Myanmar
- Malaysia
- Mozambique
- Nepal
- New Zealand
- Nigeria
- Oman
- Philippines
- Peru
- Panama
- Suriname
- Sudan
- South Korea
- Spain
- Syria
- South Africa
- Srilanka
- Thailand
- Tanzania
- Taiwan
- USA
- Uruguay
- Vietnam
- Zimbabwe
- Zambia



Smart solutions.  
Strong relationships.



**AVANTHA**  
GROUP COMPANY

## Crompton Greaves Limited

### Switchgear Complex

A-3, MIDC, Ambad, Nashik - 422 010 India

Tel : (+91) 253 2301661 to 674

Fax : (+91) 253 2381247

E-mail : govindaraj.sethuraman@cgglobal.com

URL : www.cgglobal.com

**Regd. Office** : 6th Floor, CG House,  
Dr. Annie Besant Road, Worli, Mumbai - 400 030, India.

Cat. No. SF6 -113 (3/12/1K) / Sangam